



# PCM5

## TWO- AND THREE-WAY PRESSURE COMPENSATOR WITH FIXED ADJUSTMENT

### SERIES 11

#### MODULAR VERSION ISO 4401-05

p max **350** bar  
Q max **100** l/min

#### MOUNTING INTERFACE

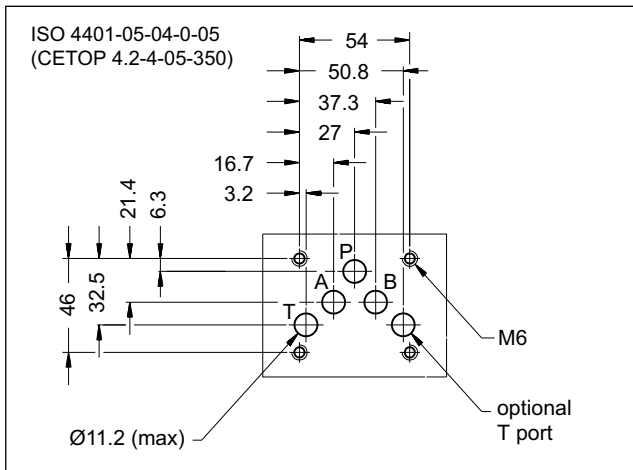

#### APPLICATION EXAMPLES

2-way compensator combined with a proportional valve type DSE5-A\*

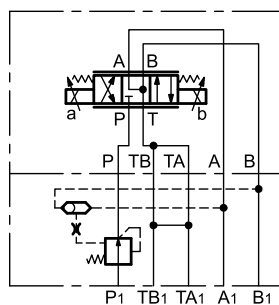

#### OPERATING PRINCIPLE

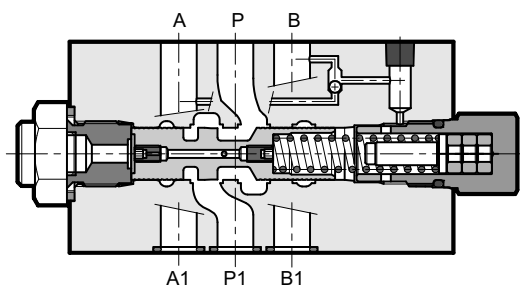

- The PCM5 valve is a two- or three- way pressure compensator, designed as a modular version with mounting surface according to ISO 4401-05.
- It keeps the pressure drop setting (characteristic  $\Delta p$ ) between the line P and alternatively the lines A and B at a constant level.
- It is used together with proportional directional valves, in order to control the flow rate independently of the pressure variations.
- The selection of the piloting pressure on the lines A and B is carried out automatically via a shuttle check valve built into the compensator.
- They are available with fixed adjustment (characteristic  $\Delta p$ ) of 4 and 8 bar.

#### PERFORMANCES

(working with mineral oil of viscosity of 36 cSt at 50°C)

Max operating pressure	bar	350
Characteristic $\Delta p$	bar	4 - 8
Max flow rate	l/min	100
Ambient temperature range	°C	-20 / +60
Fluid temperature range	°C	-20 / +80
Fluid viscosity range	cSt	10 ÷ 400
Fluid contamination degree	According to ISO 4406:1999 class 20/18/15	
Recommended viscosity	cSt	25
Mass	kg	2,7

#### HYDRAULIC SYMBOL

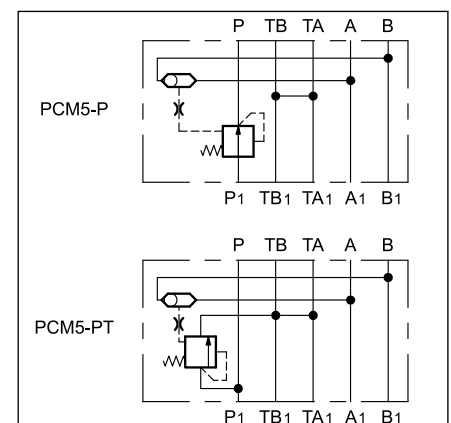



## 1 - IDENTIFICATION CODE

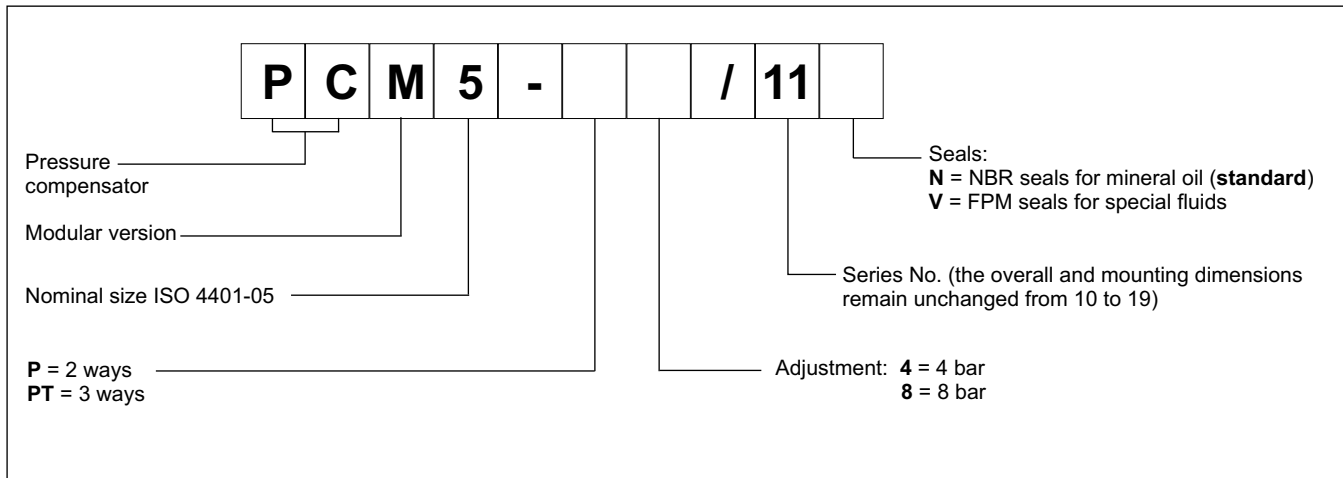

## 2 - CHARACTERISTIC CURVES PCM5-P\* (2-WAY)

(values obtained with viscosity of 36 cSt at 50°C)

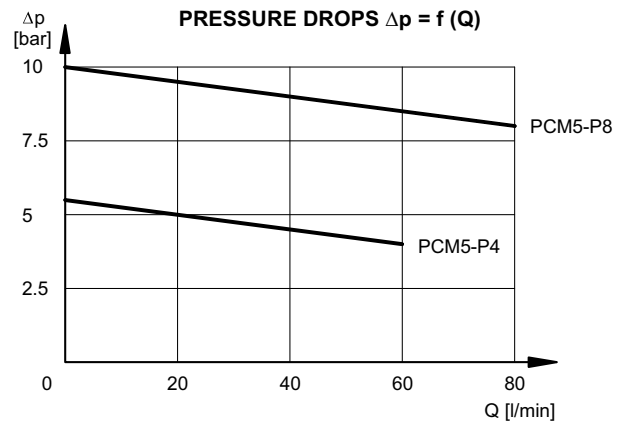
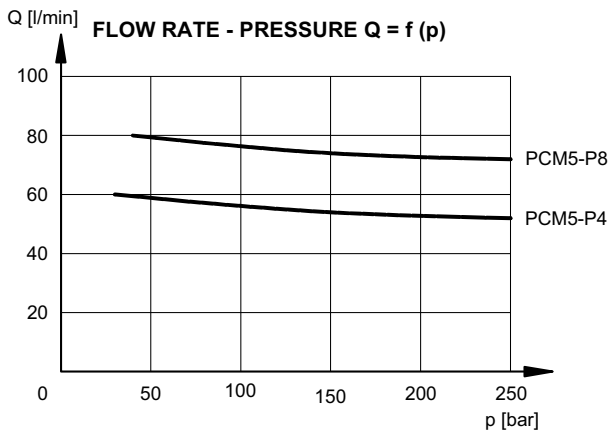

## 3 - CHARACTERISTIC CURVES PCM5-PT8 (3-WAY)

(values obtained with viscosity of 36 cSt at 50°C)

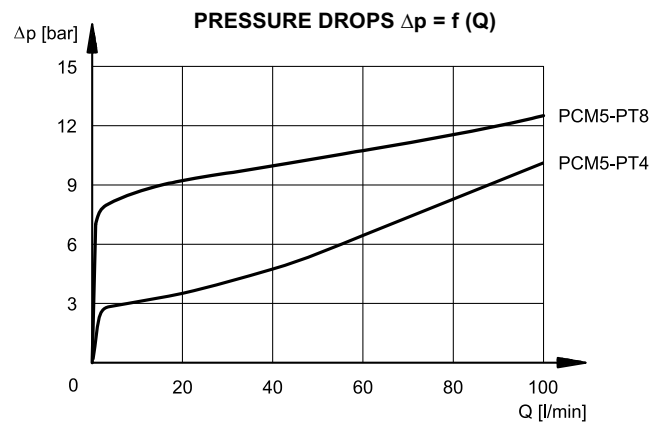
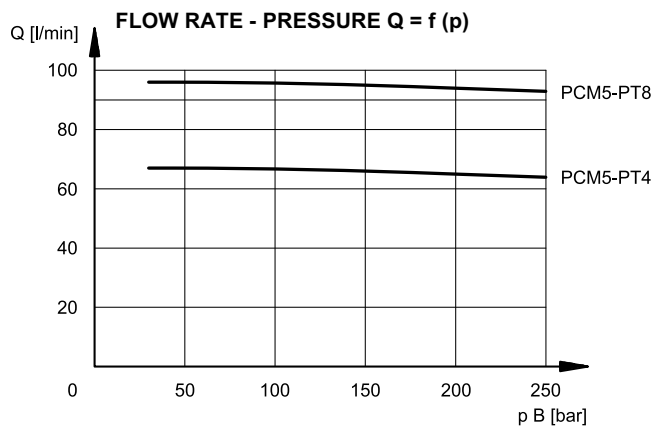

## 4 - HYDRAULIC FLUIDS

Use mineral oil-based hydraulic fluids HL or HM type, according to ISO 6743-4. For these fluids, use NBR seals (code N). For fluids HFDR type (phosphate esters) use FPM seals (code V). For the use of other kinds of fluid such as HFA, HFB, HFC, please consult our technical department.

Using fluids at temperatures higher than 80 °C causes a faster degradation of the fluid and of the seals characteristics. The fluid must be preserved in its physical and chemical characteristics.

## 5 - OVERALL AND MOUNTING DIMENSIONS

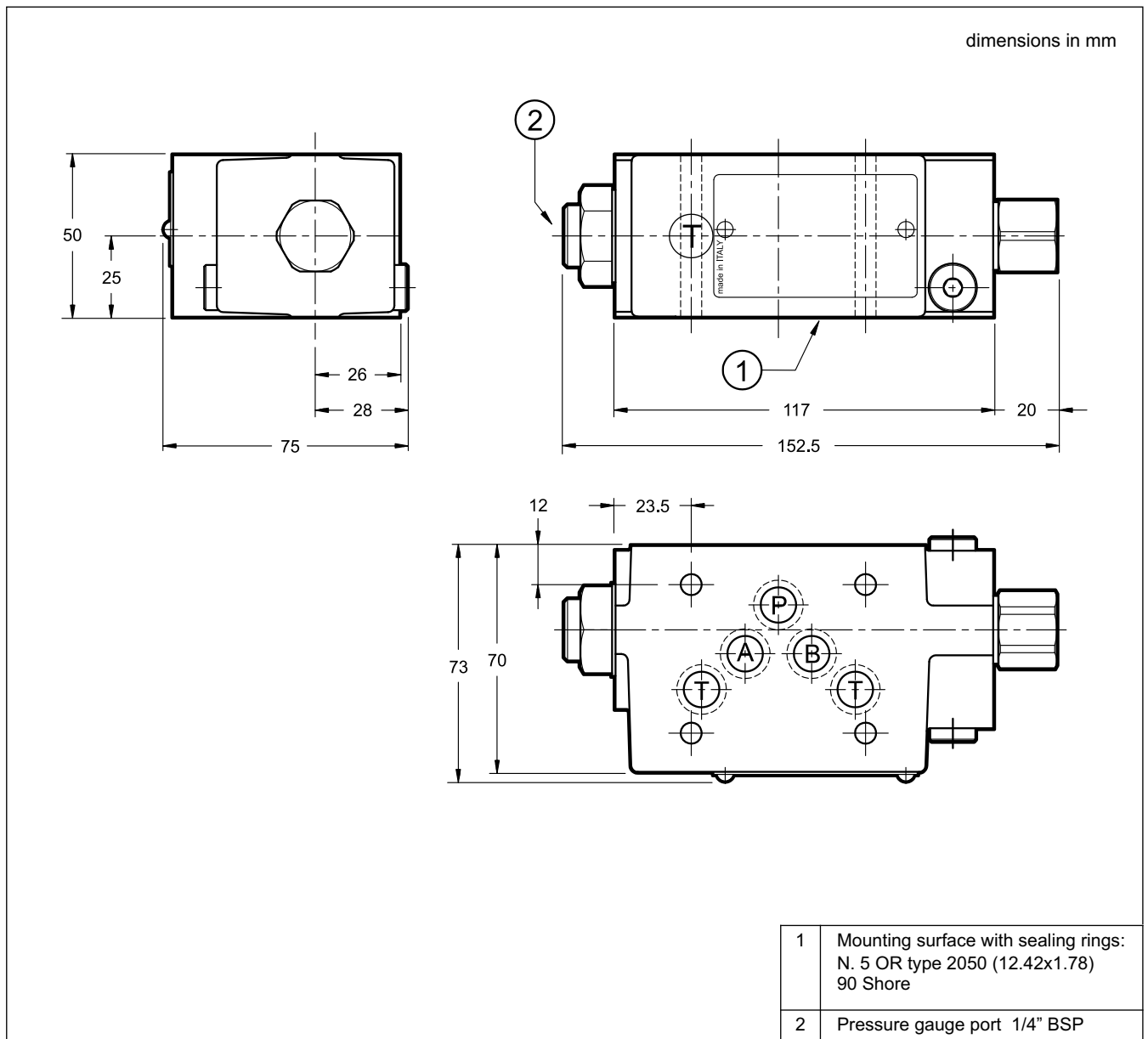



# PCM5

SERIES 11



**DIPLOMATIC MS S.p.A.**

via M. Re Depaolini 24 • 20015 PARABIAGO (MI) • ITALY  
tel. +39 0331.895.111 • [www.diplomatic.com](http://www.diplomatic.com) • e-mail: [sales.exp@diplomatic.com](mailto:sales.exp@diplomatic.com)