

Technical Data Sheet



PB473 SERIES POWER TAKE-OFF

Rear Mount PTO for Mercedes Benz

The 473 series is designed for certain Mercedes Benz transmissions with rear openings, it is a two gear PTO design.

Well proven air shift mechanism for trouble free operation. Flange matched to the transmission output.

Suits:

Mercedes Benz G131, G210, G211, G230, G231, G240, G241, G260 and G330 transmissions.
(Refer to the eGuide Configurator on www.hydreco.com for confirmation and details)

Product Features

- **Output Speeds 93.7 to 198% of Engine Speed (Model and Range Dependant)**
Provides good speeds for pump fitment.
- **Standard Outputs**
For flexibility in applications
- **Non Standard Rear Mount**
Suits certain Mercedes Benz transmissions.
- **Standard DIN 4 Bolt Rear Mount**
For ease of fitment
- **Deep Groove Ball Bearings on Output Shaft**
For longer life and higher performance.

POWAUTO

DAVID BROWN
HYDRAULICS

HYDRECO®

HYDRECO
POWAUTO
ADVANCED HYDRAULIC TECHNOLOGIES

www.hydreco.com

Technical Data Sheet

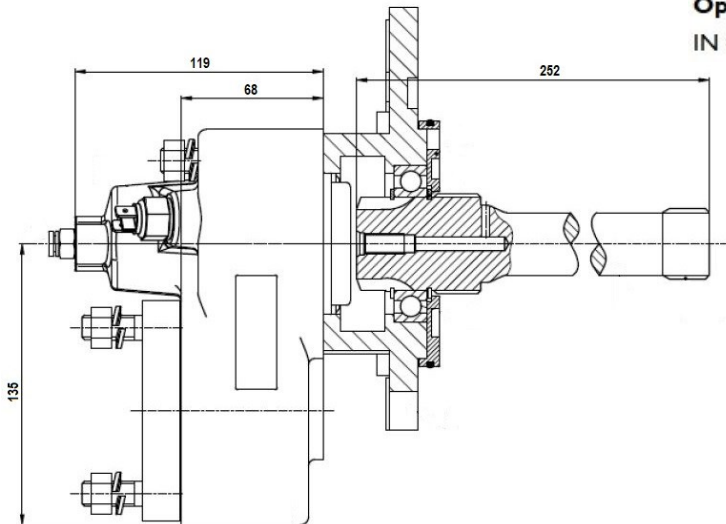
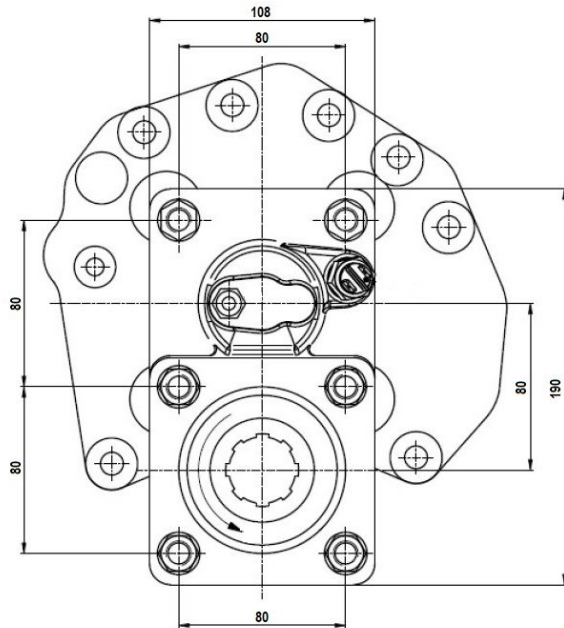

PTO DESIGNATION CODES

473 Series

PB 473 A 23 IN

Identifier

PB = PTO Rear Mount

PTO Series

473

Engagement Type

A = Air

Output Type

23 = 8T Ø36 DIN 5462 Spline - Female and DIN Mount

Options

IN = Intarder fitted to transmission

Technical Specifications		
Ratings & Service Parts		
Torque	Nm / ft.lb	300 / 221
Power @ 500 rpm	kW / hp	16.0 / 21.4
Power @ 1000 rpm	kW / hp	32.0 / 42.9
Output Shaft Rotation		Same as Engine
Approximate Bare Mass	kg / lb	13.5 / 29.7
Mounting Kit		Included
Seal Kit		

Note: For full details refer to the owners manual or the eGuide configurator found at www.hydreco.com/markets/transport

Doc: PB473—08/17

POWAUTO

DAVID BROWN
HYDRAULICS

HYDRECO®

HYDRECO
POWAUTO
ADVANCED HYDRAULIC TECHNOLOGIES

www.hydreco.com