

Technical Data Sheet



PB455 SERIES POWER TAKE-OFF

Product Features

Rear Mount PTO for ZF

The 455 series is designed for certain ZF transmissions with rear openings, it has a straight through output for extra torque in critical applications.

Continuing Hydreco Powauto's commitment to maximum torque output this PTO's design has higher specifications than most similar competing PTO's.

Suits:

ZF 16S-151, 16S-221, 16S-251 & 8S-151 transmissions.

(Refer to the eGuide Configurator on www.hydreco.com for confirmation and details)

- **Standard Outputs**
For flexibility in applications
- **Standard Rear 4 Bolt Mount**
For ease of fitment.
- **Straight Through Output**
Fewer moving parts for greater reliability and higher torque.

POWAUTO

DAVID BROWN
HYDRAULICS

HYDRECO

HYDRECO
POWAUTO
HYDRAULIC SOLUTIONS PROVIDER

www.hydreco.com

Technical Data Sheet

PTO DESIGNATION CODES

455 Series

PB 455 A 23

Identifier

PB = PTO Rear Mount

PTO Series

455

Engagement Type

A = Air

Output Type

08 = 8T Powauto Hydraulic Spline

23 = 8T Ø36 DIN 5462 Spline - Female and DIN Mount

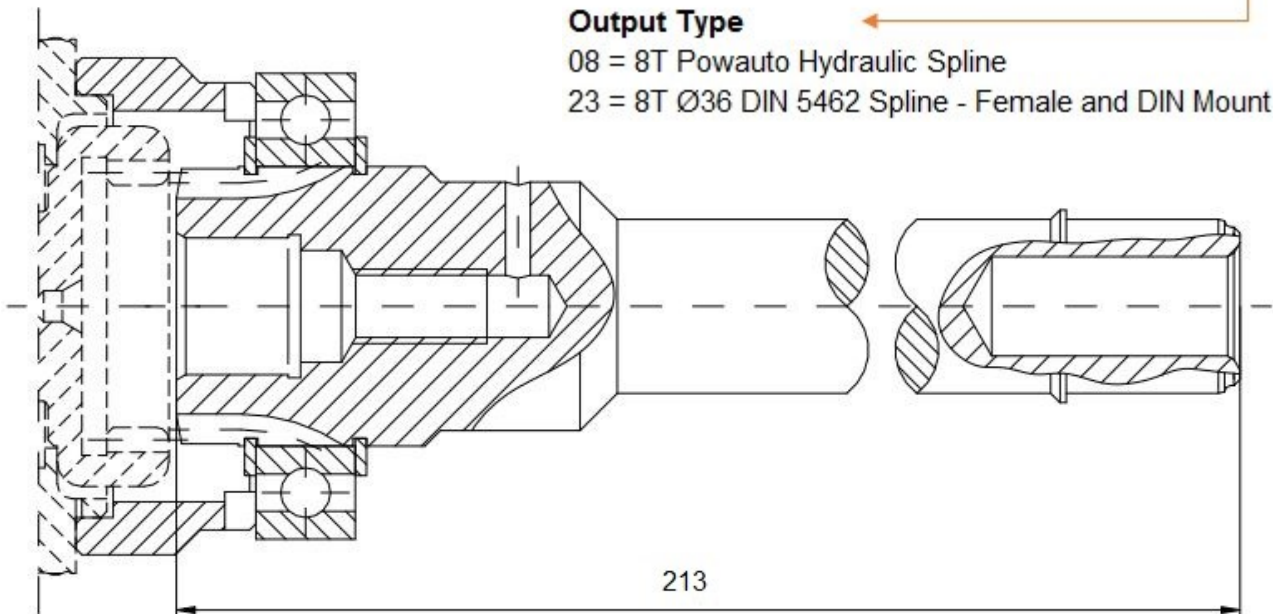

Technical Specifications		
Ratings		
Torque	Nm / ft.lb	420 / 310
Power @ 500 rpm	kW / hp	22.0 / 29.4
Power @ 1000 rpm	kW / hp	44.0 / 59.0
Output Shaft Rotation		Opposite to Engine
Approximate Bare Mass	kg / lb	4.2 / 9.2
Mounting Kit		Included

Note: For full details refer to the owners manual or the eGuide configurator found at www.hydreco.com/markets/transport

DISTRIBUTOR:

Doc: PB455—03/17

POWAUTO

DAVID BROWN
HYDRAULICS

HYDRECO

HYDRECO
POWAUTO
HYDRAULIC SOLUTIONS PROVIDER

www.hydreco.com