

Technical Data Sheet

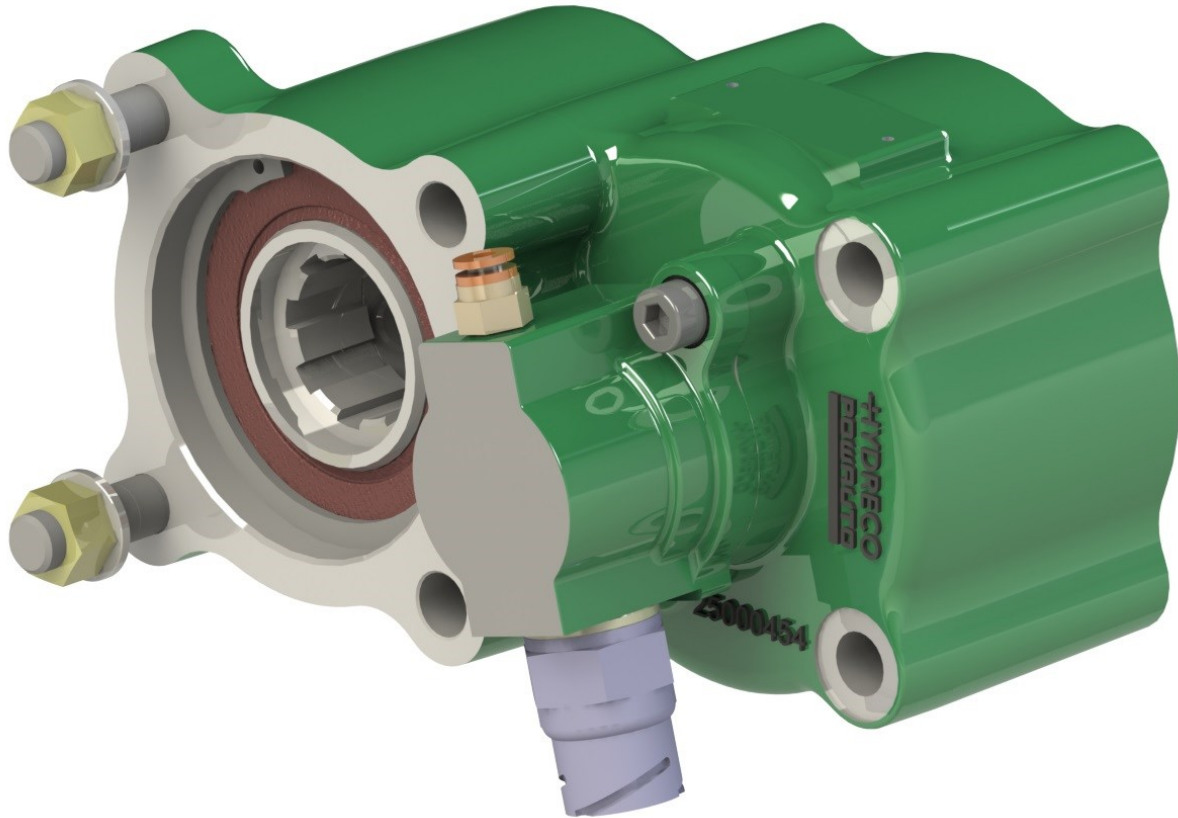

PB152 SERIES POWER TAKE-OFF

Rear Mount PTO

The 152 series PTO is designed to suit rear of counter shaft apertures.

Suitable for many transmissions, most commonly used on European trucks, this PTO is available in a number of configurations.

Suits:

Eaton, Mercedes, Volvo and ZF transmissions.
(Refer to the eGuide Configurator on www.hydreco.com for confirmation and details)

Product Features

- **Output Speeds 60 to 177% of Engine Speed (Transmission Dependant)**
Provides good speeds for pump fitment.
- **Standard Outputs**
For flexibility in applications
- **Simple Design**
For ease of fitting.
- **Standard DIN 4 Bolt Rear Mount**
For ease of fitment
- **Fully Supported & Sealed Output Gear**
To allow fitment of pumps without outboard bearings. For longer life and higher performance.

POWAUTO

DAVID BROWN
HYDRAULICS

HYDRECO®

HYDRECO
POWAUTO

ADVANCED HYDRAULIC TECHNOLOGIES

www.hydreco.com

Technical Data Sheet

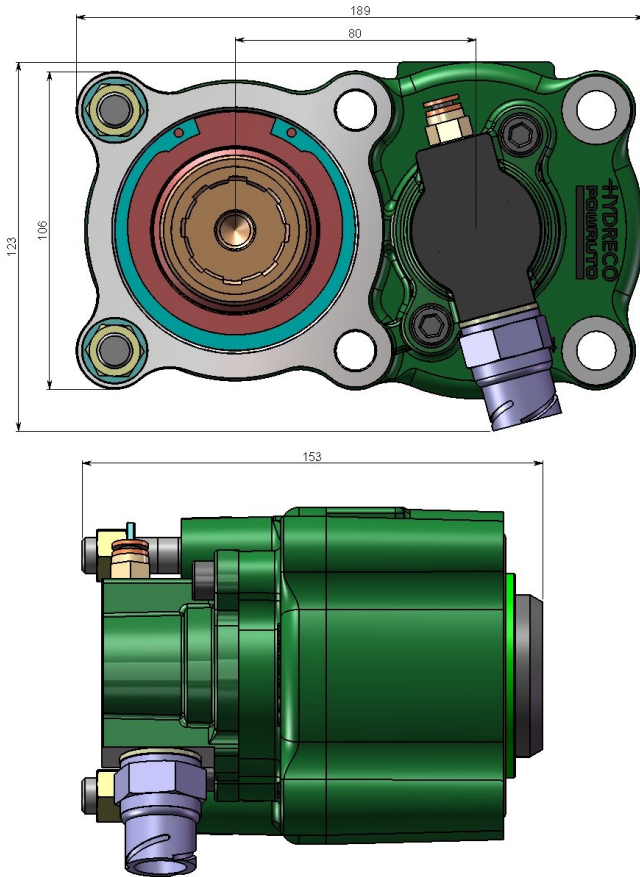

PTO DESIGNATION CODES

152 Series

PB 152-2 A 23 A

Identifier

PB = PTO Rear Mount

PTO Series

152-1, 152-2, 152-3

Engagement Type

A = Air

Output Type

08 = 8T Powauto Hydraulic Spline

23 = 8T Ø36 DIN 5462 Spline - Female and DIN Mount

Other outputs available on request, subject to MOQ.

Manufacturers Code

A = With Switch

Technical Specifications		
Ratings & Service Parts		
Torque	Nm / ft.lb	325 / 240
Power @ 500 rpm	kW / hp	17.0 / 22.8
Power @ 1000 rpm	kW / hp	34.0 / 45.6
Output Shaft Rotation		Same as Engine
Approximate Bare Mass	kg / lb	8.5 / 18.7
Mounting Kit		* See Note
Seal Kit		SK084A
Repair Kit		BK084A

* Mounting kit varies with transmission - refer to eGuide Configurator.

Note: For full details refer to the owners manual or the eGuide configurator found at www.hydreco.com/markets/transport

Doc: PBI52—02/18

POWAUTO

DAVID BROWN
HYDRAULICS

HYDRECO®

HYDRECO
POWAUTO

ADVANCED HYDRAULIC TECHNOLOGIES

www.hydreco.com