

# Technical Data Sheet

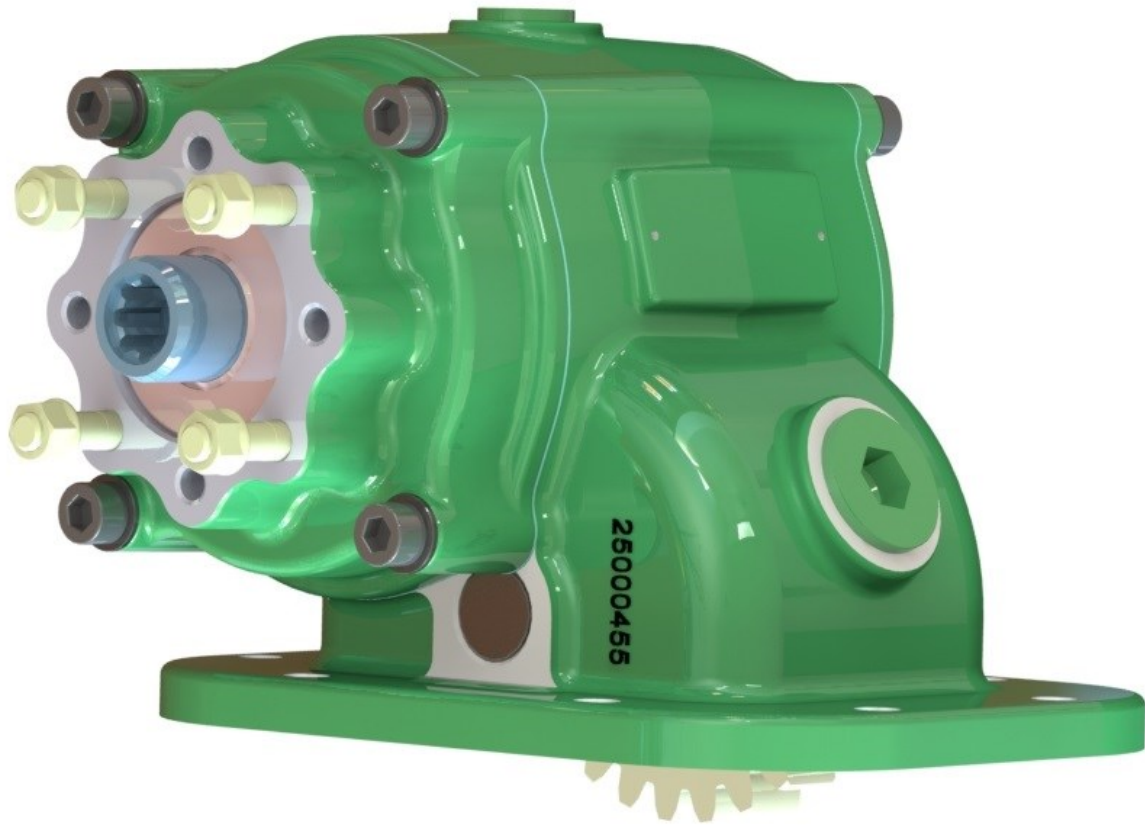

## PA4900 SERIES POWER TAKE-OFF

### SAE 8 Bolt Side Mounted Hotshift PTO

Designed for transmissions with SAE 8 bolt openings, the 4900 series PTO has an output ratio suitable for high torque in critical applications.

Built with constant mesh gearing, this PTO incorporates a clutch pack to engage and disengage the output shaft.

With optimised ratios this PTO will provide extra torque for normal engine speeds.

#### Suits:

Eaton Fuller transmissions.  
(Refer to the eGuide Configurator on [www.hydreco.com](http://www.hydreco.com) for confirmation and details)

## Product Features

- **Viton Seals and O-Rings**  
For compatibility with high temp conditions.
- **Secondary Rear Cover**  
To allow seal changes in situ, resulting in more up time.
- **Tapered Roller Bearings**  
To provide durability under all conditions.
- **Improved Return Spring**  
To reduce drag and extend service life.
- **Internal Clutch System**  
For effortless engagement on the go.
- **Ideal For Applications With Frequent Engagements**

POWAUTO

DAVID BROWN  
HYDRAULICS

HYDRECO®

HYDRECO  
POWAUTO

ADVANCED HYDRAULIC TECHNOLOGIES

[www.hydreco.com](http://www.hydreco.com)

# Technical Data Sheet

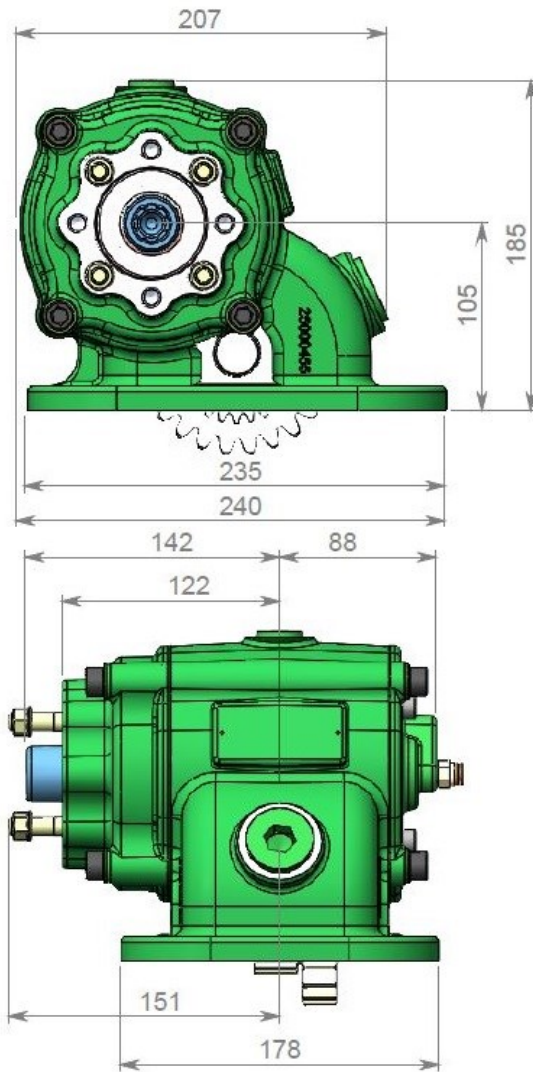

## PTO DESIGNATION CODES

### 4900 Series

PA 4902 B L I I A 08 \*

#### Identifier

PA = PTO Side Mount

#### PTO Series

49

#### Ratio

02

#### Gear Type

B

#### Build

L = Left side of transmission

R = Right side of transmission

1 = Selector to top / Bias to bottom

2 = Selector to bottom / Bias to top

I = Centre to front

(Position of gear in transmission)

#### Engagement Type

A = Air

#### Output Type

08 = 8T Powauto Hydraulic Spline

10 = 14T 12/24 30° Spline + 1310 Flange

11 = 14T 12/24 30° Spline + 1410 Flange

13 = 13T SAE B Hydraulic Spline + SAE B Pump Mount

23 = 8T Ø36 DIN 5462 Spline - Female and DIN Mount

Other outputs available on request, subject to MOQ.

#### Manufacturers Code

A = With Pressure Switch

Technical Specifications		
Ratings & Service Parts		
Torque	Nm / ft.lb	417 / 306
Power @ 500 rpm	kW / hp	21.8 / 29.2
Power @ 1000 rpm	kW / hp	43.6 / 58.5
Output Shaft Rotation		Opposite To Engine
Approximate Bare Mass	kg / lb	20.0 / 44.0
Mounting Kit		* See note
Mounting Gasket Kit		GK002
Seal Kit		SK062B
Bearing Kit		BK062B

\* Mounting kit varies with transmission - refer to eGuide Configurator.

**Note:** For full details refer to the owners manual or the eGuide configurator found at [www.hydreco.com/solutions/on-road](http://www.hydreco.com/solutions/on-road)

Doc: PA4900—05/18

POW AUTO

DAVID BROWN  
HYDRAULICS

HYDRECO®

HYDRECO  
POW AUTO

ADVANCED HYDRAULIC TECHNOLOGIES

www.hydreco.com