



# UEIK-2\*

## ELECTRONIC CONTROL UNIT FOR OPEN LOOP DOUBLE SOLENOID PROPORTIONAL VALVE

SERIES 51

### EUROCARD TYPE

### FUNCTIONAL BLOCK DIAGRAM

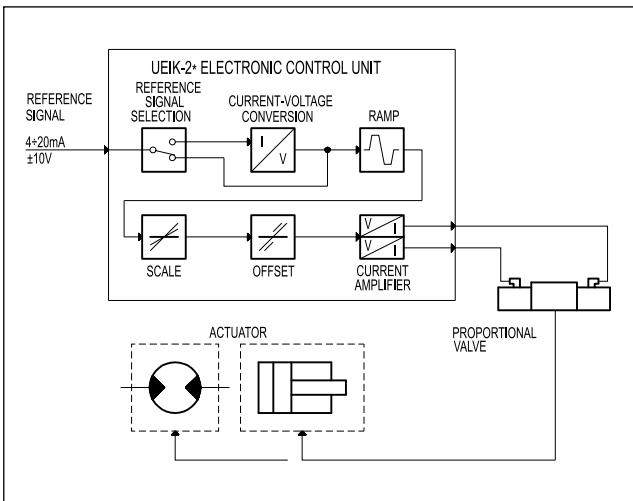

### TECHNICAL CHARACTERISTICS

Power supply	V DC	22 ÷ 30 Ripple included
Required power	see paragraph 2.1	
Output current	see paragraph 3.3	
Power supply electrical protection	– overload – polarity inversion	
Reference signal: – Voltage – Current	V mA	± 10 4 ÷ 20
Input reference signal impedance: – Voltage – Current	kohm ohm	10 250
Electromagnetic compatibility (EMC) (see par. 5 - NOTE 1)	in compliance with 2014/30/EU	
Card size	Eurocard 100x160x35	
Connector interface	DIN 41612-D 32 Male	
Operating temperature range	°C	0 ÷ 50
Mass	kg	0,27

### FRONT PANEL

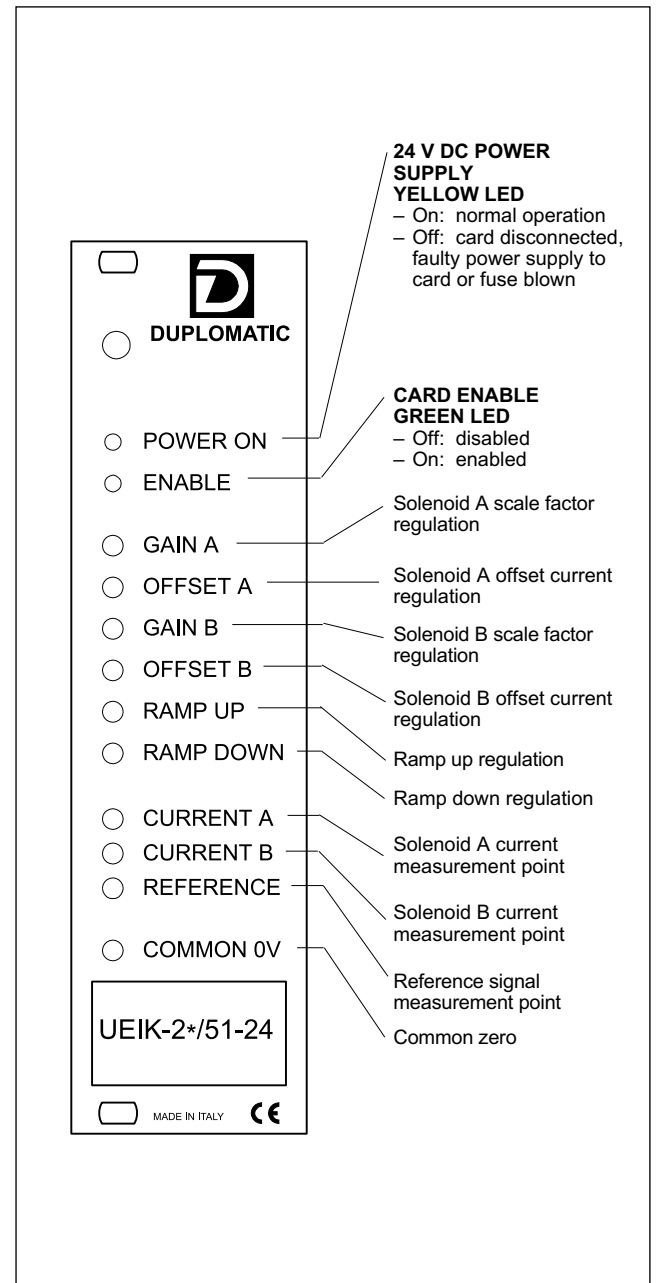

### 1 - IDENTIFICATION CODE

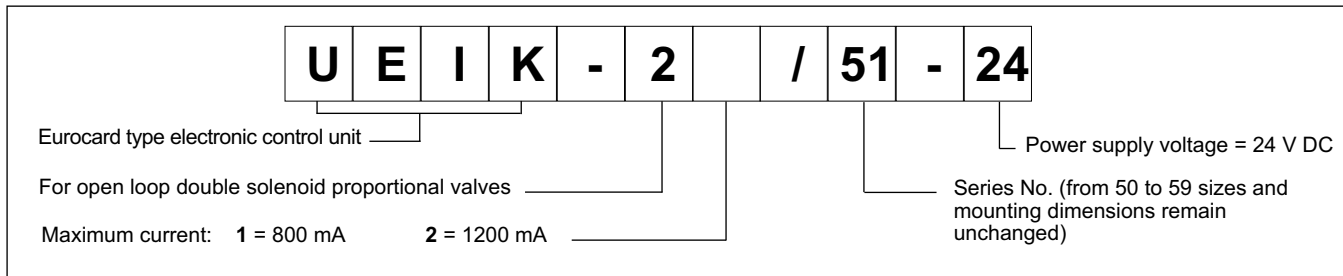

The UEIK-2\* card is an electronic control unit Eurocard type for open loop of double solenoid proportional valves.

The unit supplies a variable current in proportion to the input reference signal and independently of temperature variations or load impedance.

The PWM stage on the solenoid power supply makes it possible to reduce valve hysteresis thus optimising control precision. The front panel is fitted with LEDs to indicate card functions and potentiometers to optimize control.

### 2 - FUNCTIONAL SPECIFICATIONS

#### 2.1 - Electric power supply

The card requires a power supply of between 22 and 30 V DC (pin 2a/2c - 4a/4c) and 20 W (UEIK-21) - 29 W (UEIK-22).

Power supply voltage must be rectified and filtered, with maximum admissible ripple within the above voltage range.

#### 2.2 - Electrical protection

The card is protected against overvoltage and polarity inversion.

A 2A fast-acting fuse is fitted for power circuit protection.

#### 2.3 - Reference signal

The card accepts voltage reference signals ( $\pm 10V$ ) or current reference signals ( $4 \div 20$  mA).

**NOTE: If the signal is transmitted by potentiometer, please verify that this has a load of at least 200  $\Omega$ .**

See paragraph 9 for electrical connections.

The diagram shows characteristics of current supplied according to the reference signal.

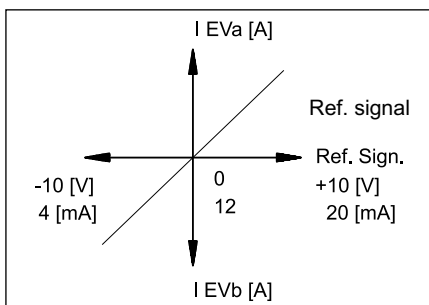

### 3 - SIGNALS AND ADJUSTMENT

#### 3.1 - POWER ON

The yellow LED indicates card power supply:  
 ON - normal power supply  
 OFF - no power supply, faulty power supply or blown fuse

#### 3.2 - ENABLE

A 22 to 30 V DC on pin 24c enable command is required for card operation.  
 The condition of the enable card is shown by both a visible LED on the front panel and as a contact available for the user on pins 6a and 6c.

The green LED indicates:  
 ON - card enabled  
 OFF - card disabled or failed

#### 3.3 - GAIN A / GAIN B (Scale factor regulation of solenoids A and B)

"GAIN A" and "GAIN B" potentiometers enable regulation of the ratio between the set reference value and current supplied to solenoids A and B respectively. This enables independent regulation of the controlled parameter in the two valve hydraulic configurations.

The maximum current of the card is limited to 1,0A (UEIK-21) - 1,2A (UEIK-22). See par. 6 for default values.

Rotate clockwise to increase current.

#### 3.4 - OFFSET A / OFFSET B (Polarization current regulation of solenoids A and B)

"OFFSET A" and "OFFSET B" potentiometers enable regulation of the offset current of the valve solenoids A and B respectively. They are used to eliminate the valve insensitivity zone (dead zone) in the two valve hydraulic figures.

The regulation range is from 0 to 0,5A (UEIK-21) - from 0 to 0,65A (UEIK-22).

The offset current is activated when the reference signal exceeds the threshold of  $\pm 150$  mV.

The offset is not active and only the polarization current equal to 25 mA is present beneath this threshold.

**NOTE:** The variation of the set value of the offset current causes a corresponding variation of the scale factor value.

Rotate clockwise to increase current.

#### 3.5 - RAMP UP / RAMP DOWN (Ramp regulation)

"RAMP UP" and "RAMP DOWN" potentiometers, in a range from 0,03 to 7 sec., regulate the time taken to achieve the current for a step change of the reference signal up or down. They are independently adjusted and serve both solenoids.

This makes it possible to smooth valve response and adapt it to the requirements of the hydraulic system and the machine cycle.

Rotate clockwise to increase ramp time.

Ramps can be inhibited by transmitting a 22 to 30 V DC command to pin 16a. In this case, the ramp residual time is 10 ms.

#### 4 - SIGNAL MEASUREMENT

##### 4.1 - CURRENT A / CURRENT B

(Current measurement points of solenoids A and B)

Measurement points for voltage readings of current supplied to solenoids A and B. Reading conversion is 1V DC = 1A (UEIK-21) and 0,82V DC = 1A (UEIK-22).

##### 4.2 - REFERENCE (Reference signal measurement point)

Enables reading in voltage of reference signal sent to the card.

Reading is direct, but of opposite sign, with voltage reference while current conversion is: 4 mA = +10V      20 mA = -10V.

#### 5 - INSTALLATION

The card is suitable for assembly on a rack or a card holder with interface for connector types DIN 41612 - size D - 32 pole.

It is recommended to use cable sections of 1 to 2,5 mm<sup>2</sup>, in function with their length, for power supply and solenoid connections. For other connections, it is recommended to use cables with a screened sheath connected to earth only on the card side.

##### NOTE 1

To observe EMC requirements it is important that the control unit electrical connection is in strict compliance with the wiring diagram of par. 6.

As a general rule, the valve and the electronic unit connection wires must be kept as far as possible from interference sources (e.g. power wires, electric motors, inverters and electrical switches).

In environments that are critical from the electromagnetic interference point of view, a complete protection of the connection wires can be requested.

#### 6 - DEFAULT CONDITIONS

The electronic control unit is supplied factory-set.

Standard settings are:

- "GAIN A" regulation: +10V (or 20 mA) reference signal corresponding to a current supply of 0,82 A to solenoid A.
- "GAIN B" regulation: -10V (or 4 mA) reference signal corresponding to a current supply of 0,82 A to solenoid B.
- "OFFSET A" or "OFFSET B" regulation: zero
- "RAMP UP" and "RAMP DOWN" regulation: minimum
- position SW1 on V
- position SW2 on S
- position SW3 on AA
- switching frequency (PWM) = 200Hz (UEIK-21)  
100Hz (UEIK-22)

#### 7 - START-UP AND FRONTAL SETTINGS

If required, settings can be adjusted as follows:

##### a) OFFSET CURRENT REGULATION

(Note: the same procedure applies to channels A and B on the card)

- Set "GAIN A" or "GAIN B" potentiometer to minimum.
- Enter reference signal at maximum value:
  - +10V (or 20 mA) for solenoid A
  - 10V (or 4 mA) for solenoid B.
- Regulate "OFFSET A" or "OFFSET B" potentiometer so that the valve is positioned at the start of the relative hydraulic configuration work zone.

##### b) SCALE FACTOR REGULATION

(NOTE: the same procedure applies to channels A and B on the card)

- Enter the reference signal at maximum value
  - +10V (or 20 mA) for solenoid A
  - 10V (or 4 mA) for solenoid B.
- Adjust "GAIN A" and "GAIN B" potentiometers until the size controlled in the relative hydraulic configuration reaches the maximum required value.

**NOTE: The maximum current value must be compatible with the maximum current prescribed by the technical table of the connected proportional valve.**

##### c) RAMP REGULATION

- Regulate the "RAMP UP" and "RAMP DOWN" potentiometers to obtain the required valve smoothness of movement with a reference variation.

#### 8 - CARD CIRCUIT SETTINGS

The overall dimension diagram in par. 10 shows three switch banks: SW 1 - SW 2 - SW 3 which enable card set up as required.

**NOTE: Each modification to switch settings must be carried out with the card disconnected from the power supply. The individual switches inside each bank must all be set in the same position.**

SELECTION OF VOLTAGE OR CURRENT REFERENCE SIGNAL (SW 1 bank comprising three individual switches)

- select V for voltage reference signal
- select I for current reference signal.

SELECTION OF SINGLE ENDED OR DIFFERENTIAL REFERENCE SIGNAL (SW 2 bank comprising one individual switch)

- select S for single ended reference signal. This condition is obligatory in the case that the reference signal is generated with an external potentiometer fed by the card itself.
- select D for differential reference signal. This signal is preferable in the case that the reference signal comes from a PLC or CNC analogic outlet.

**NOTE: The SW 3 bank, comprising two individual switches, must always be set at AA as per standard supply conditions.**

SWITCHING FREQUENCY ADJUSTMENT

It is possible to change the switching frequency (PWM) by acting on the trimmer PT7 (see par. 10).

The setting range is from 80 to 370 Hz.

An appropriate switching frequency adjustment allows reduction of the valve hysteresis value.

Clockwise rotation to increase the frequency.



## 9 - CARD CIRCUIT AND WIRING DIAGRAMS

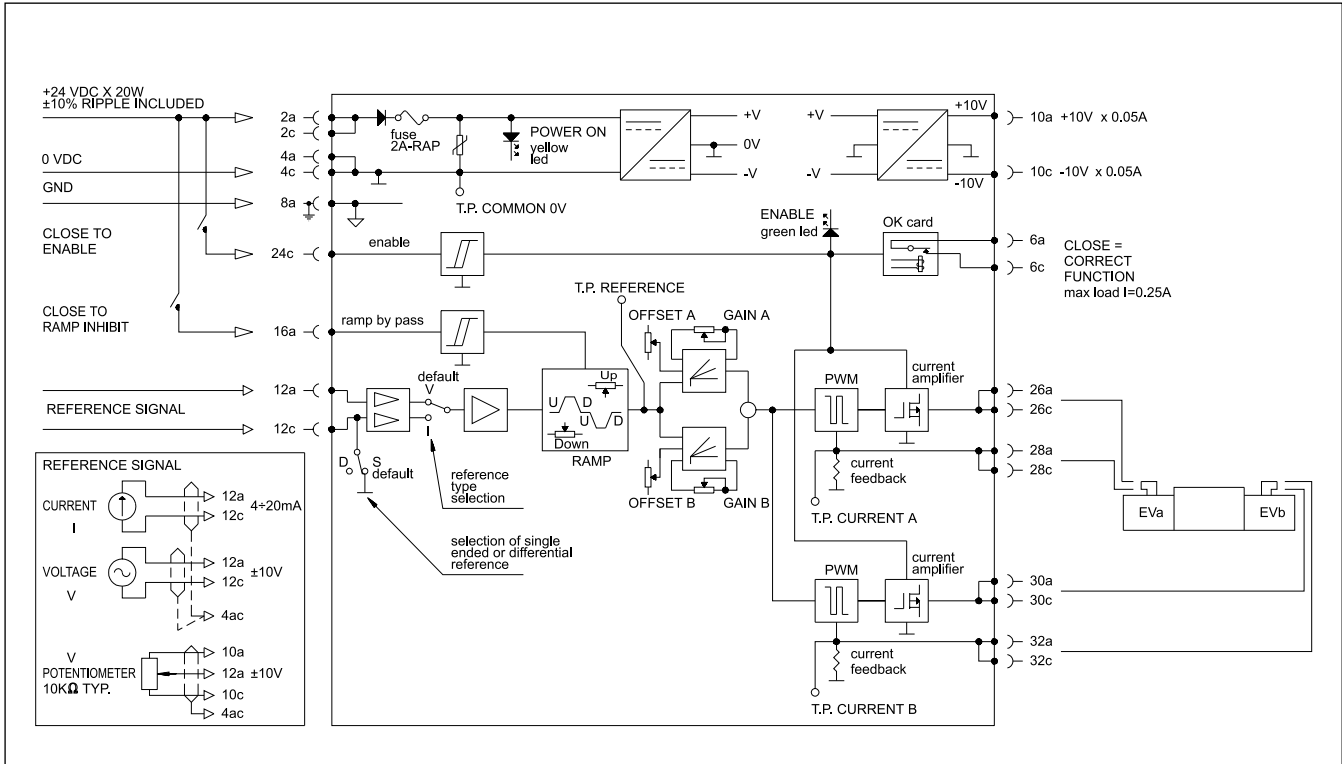

## 10 - OVERALL AND MOUNTING DIMENSIONS

