

DXE5J

HIGH RESPONSE SERVO-PROPORTIONAL VALVE WITH FEEDBACK AND INTEGRATED ELECTRONICS SERIES 31

**SUBPLATE MOUNTING
ISO 4401-05**

**p max 350 bar
Q max 100 l/min**

MOUNTING INTERFACE

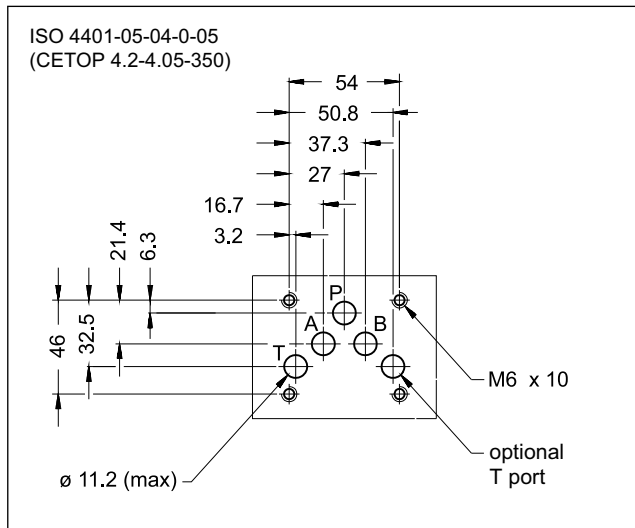

OPERATING PRINCIPLE

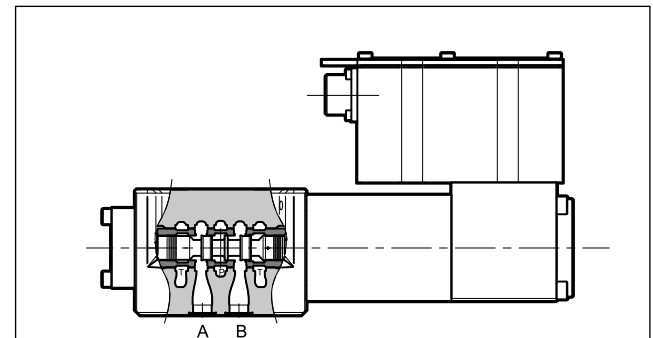

- The DXE5J valve is a four-way (3 + fail-safe position) servo-proportional valve where the spool moves inside a sleeve. It is operated by a proportional solenoid highly dynamic, which achieves high performance and not requires pilot pressure. The spool position is controlled by a linear transducer (LVDT) in closed loop, which ensures high precision and repeatability.

- It is available with two flow ranges up to 100 l/min with spools with zero overlap.

- A version for potentially explosive atmospheres according to ATEX 2014/34/EU II 3GD is available.

- The valve is featured by integral electronic based on SMD technology which ensures standard regulations and simplifies the electric wiring. The unit does not require any adjustment other than the possible electronic regulation of the zero.

- Suitable for control applications with closed loop of position, velocity and pressure. If the valve is not powered or is without the enable input (version A only), the spool moves automatically at fail-safe position.

PERFORMANCES

(with mineral oil of viscosity 36 cSt at 50°C)

Maximum operating pressure ports P - A - B port T	bar	350 250
Rated flow Q nom (with Δp 70 bar P - T)	l/min	60 - 100
Hysteresis	% In	< 0,2
Threshold	% In	< 0,1
Thermal drift (with $\Delta T = 40$ °C)	% In	< 1,0
Response time (0-100%)	ms	≤ 20
Vibration on the three axes	g	30
Ambient temperature range	°C	-20 / +60
Fluid temperature range	°C	-20 / +80
Fluid viscosity range	cSt	5 + 400
Fluid contamination degree	according to ISO 4406:1999 class 17/15/12 (16/14/11 for longer life)	
Recommended viscosity	cSt	25
Mass	kg	6

HYDRAULIC SYMBOL

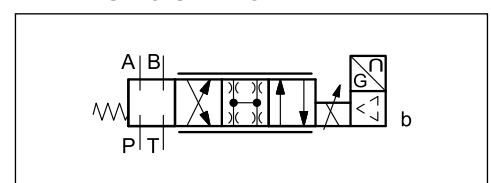

1 - IDENTIFICATION CODE

1.1 - Standard electronics

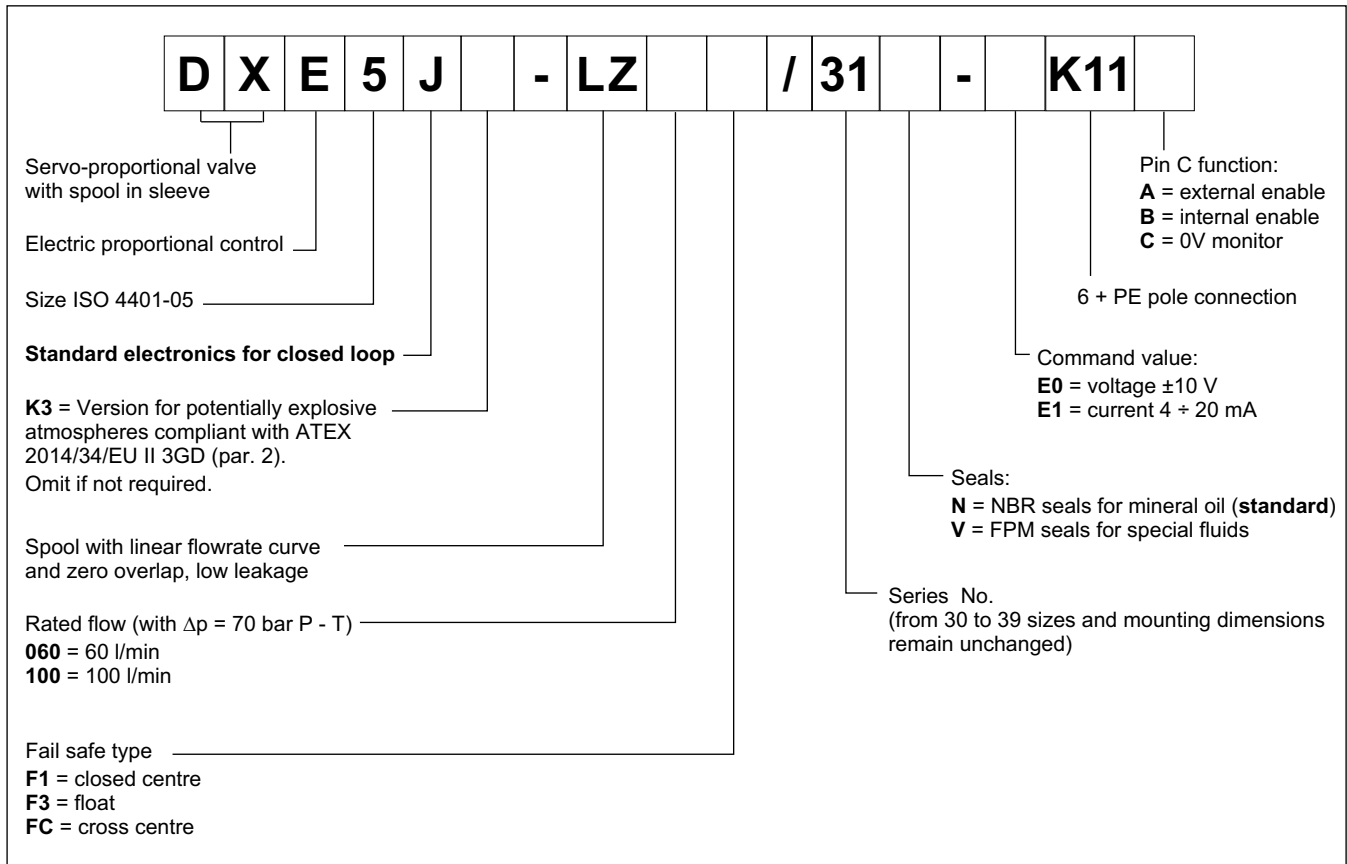

1.2 Available versions

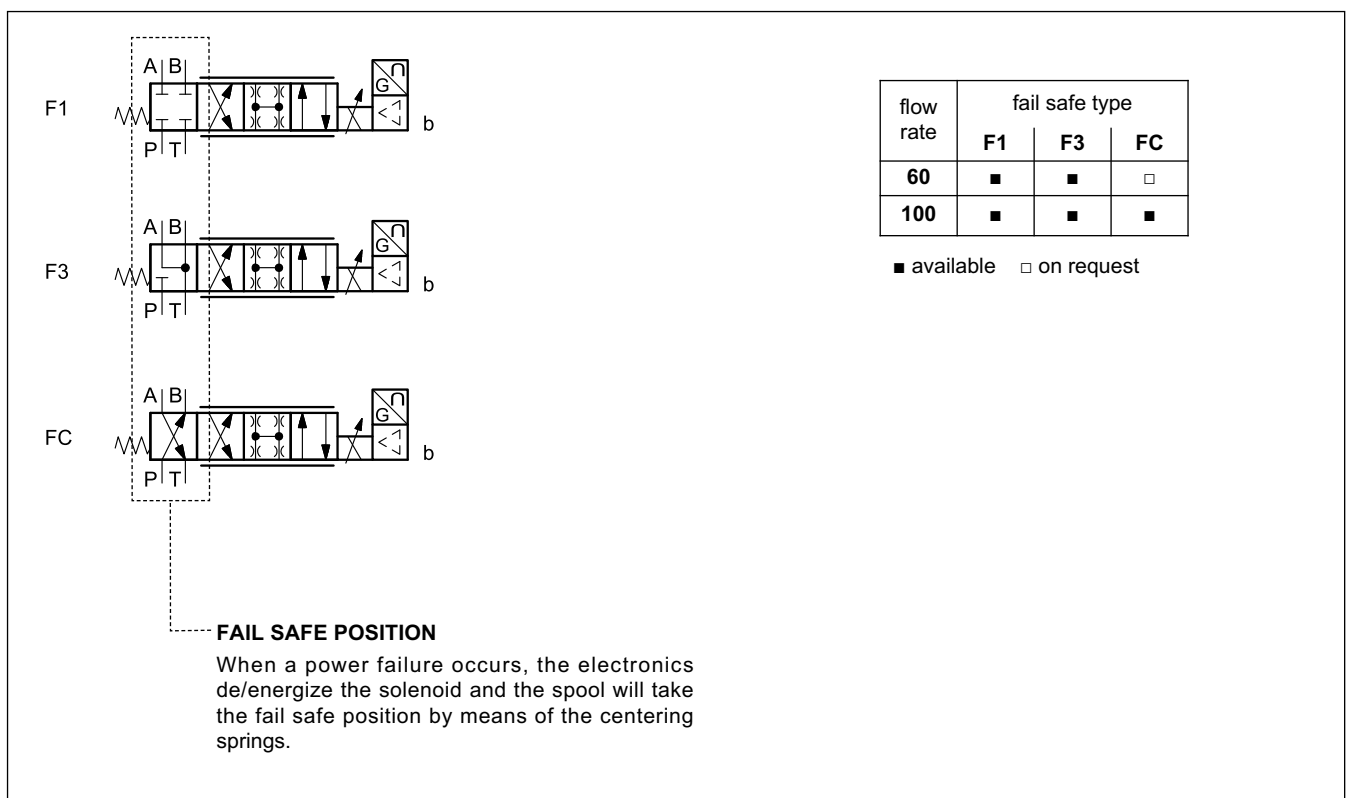



1.3 - Electronics with fieldbus communication

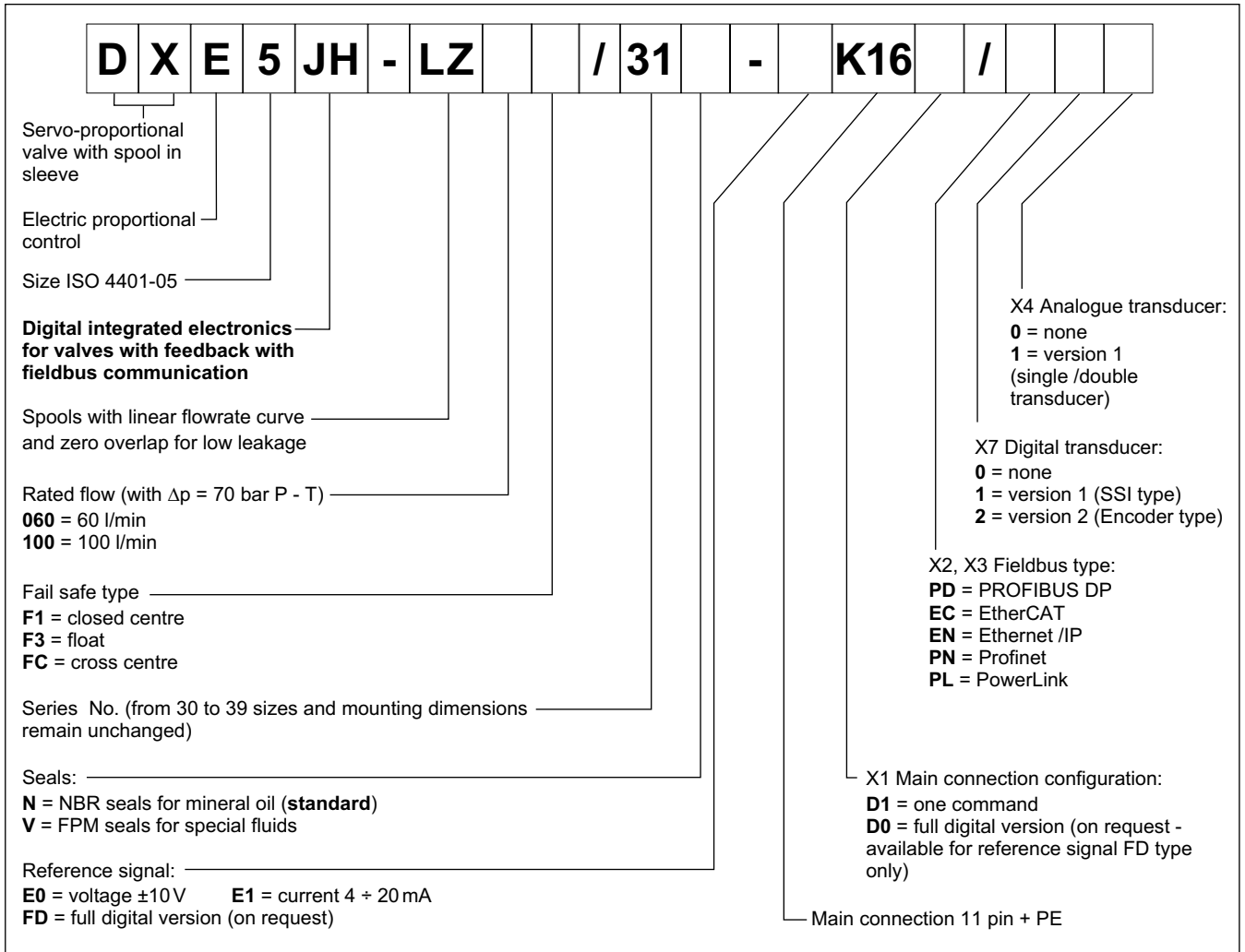

2 - ATEX 2014/34/EU RATED VERSION

Valves suitable for use in potentially explosive atmospheres certified according to ATEX 2014/34/EU classified under ATEX II 3GD are available.

The electrical and technical characteristics and dimensions of ATEX certified valves are identical to those of standard valves.

The supply is always delivered together with the ATEX declaration of conformity and the operating and maintenance user manual, where are described all the information for the proper use of valves in potentially explosive atmospheres.

TYPE EXAMINATION CERTIFICATE N°: **AR20ATEX046**

2.1 - Identification code

To order the ATEX-rated version, simply insert letters K3 in the initial part of the identification code. The description becomes DXE5JK3. Please use the identification code shown at par. 1.1 to order.

Example:

- DXE5JK3-LZ60F1/31N-E0K11A

2.2 - Classification

The valves DXE5JK3 are ATEX marked as below:

MARKING FOR GASES, VAPOURS AND MISTS:

II 3G Ex ec IIC T4 Gc

EX: Specific marking of explosion protection as ATEX 2014/34/EU directive and related technical specification requests

II: Group II for surface plants

3: Category 3 normal protection, eligible for zone 2

G: for use in areas in which explosive atmospheres caused by gases, vapours, mists

Ex ec: "ec" protection type, increased safety

IIC: Gas group

(automatically eligible for group IIA and IIB)

T4: Temperature class (max surface temperature)

Gc: Protection level for electrical devices (EPL)

Equipment for explosive gas atmospheres, having an "enhanced" level of protection, which is not a source of ignition in normal operation and which may have some additional protection to ensure that it remains inactive as an ignition source in the case of regular expected occurrences.

MARKING FOR DUSTS:

II 3D Ex tc IIIC T135°C Dc

EX: Specific marking of explosion protection as ATEX 2014/34/EU directive and related technical specification requests

II: Group II for surface plants

3: Category 3 normal protection, eligible for zone 22

D: for use in areas in which explosive atmospheres are caused by explosive dusts

Ex tc: "tc" protection type, protected by enclosures

IIIC: Dusts group

(automatically eligible for group IIIA and IIIB)

T135°C: Temperature class (max surface temperature)

Dc: Protection level for electrical devices (EPL)

Equipment for explosive dust atmospheres, having an "enhanced" level of protection, which is not a source of ignition in normal operation and which may have some additional protection to ensure that it remains inactive as an ignition source in the case of regular expected occurrences.

2.3 - IP protection degree

The IP protection degree of the valve is IP66/IP68 according to IEC EN 60529.

NOTE: the test carried out to reach IP68 is: duration 1 h, depth 1 m.

The IP degree is guaranteed only with mating connector of equivalent IP degree, installed and tightened correctly.

2.4 - Operating temperatures

The operating ambient temperature must be between -20 °C and +60 °C.

The fluid temperature must be between -20°C and +80°C.

The valves are T4 (T135 °C) class temperature classified, so they are eligible for operation also at higher class temperature (T3, T2, T1 (T200 °C)).

2.5 - Connectors

The connector is not supplied with the valve, but can be ordered separately. **The connector must be suitable for the intended conditions of use.**

Duplomatic can provide 7-pin connectors to wire, metal type, suitable for use with DXE5JK3 valves (see catalogue 89 000, connectors type EX7S).

2.6 - Grounding points

The ATEX certified valves are supplied with a grounding point with M4 screw.

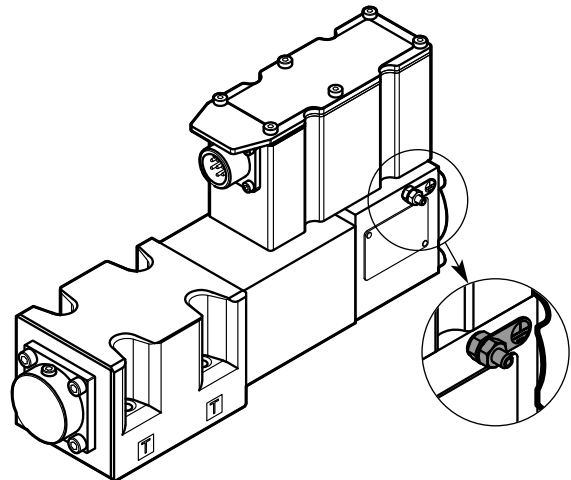

The grounding point must always be wired with the general earthing system by means of a suitable conductive line.

3 - ELECTRONICS COMMON DATA

Duty cycle		100% (continuous operation)
Protection class according to EN 60529		IP66/IP68 (NOTE)
Supply voltage	V DC	24 (from 19 to 30 VDC), ripple max 3 Vpp
Power consumption	VA	60
Maximum solenoid current	A	3.7
Fuse protection, external	A	(fast), max current 6A
Managed breakdowns		Overload and electronics overheating, LVDT sensor error, cable breakdown, supply voltage failures
Electromagnetic compatibility (EMC) emissions EN 61000-6-4, immunity EN 61000-6-2		According to 2014/30/EU standards

NOTE: The IP degree is guaranteed only with mating connector of equivalent IP degree, installed and tightened correctly. Furthermore, on the JH versions it is necessary to protect with caps any unused connections. The test carried out to reach IP68 is: duration 1 h, depth 1 m.

4 - DXE5J - STANDARD ELECTRONICS

4.1 - Electrical characteristics

Command signal:	voltage (E0) current (E1)	V DC mA	±10 (Impedance Ri = 11 kOhm) 4 ÷ 20 (Impedance Ri = 58 Ohm)
Monitor signal (current to solenoid):	voltage (E0) current (E1)	V DC mA	±10 (Impedance Ro > 1 kOhm) 4 ÷ 20 (Impedance Ro = 500 Ohm)
Communication for diagnostic			LIN-bus Interface (by means of the optional kit)
Connection			6 pin + PE (MIL-C-5015-G - DIN EN 175201-804)

4.2 - On-board electronics diagrams

VERSION A - External Enable

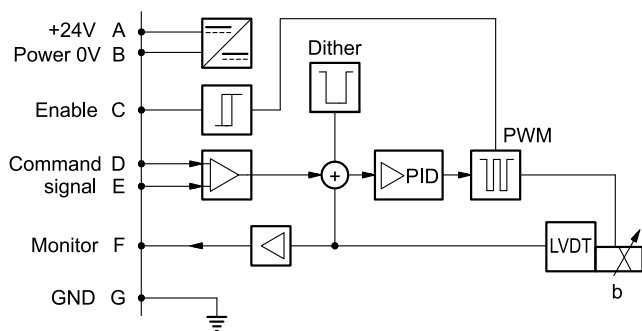

VERSION B - Internal Enable

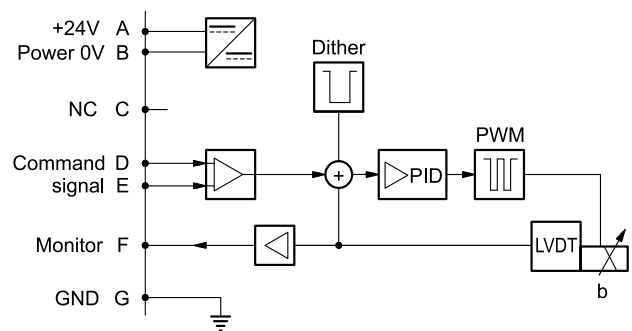

VERSION C - 0V Monitor

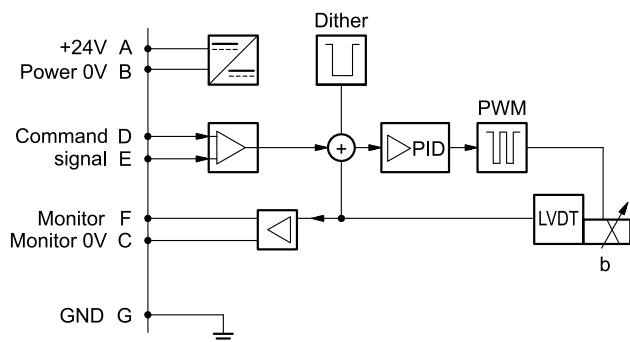

4.3 - Versions with voltage COMMAND (E0)

The reference signal must be between -10V and +10V. The monitor feature of versions B and C becomes available with a delay of 0,5 sec from the power-on of the card.

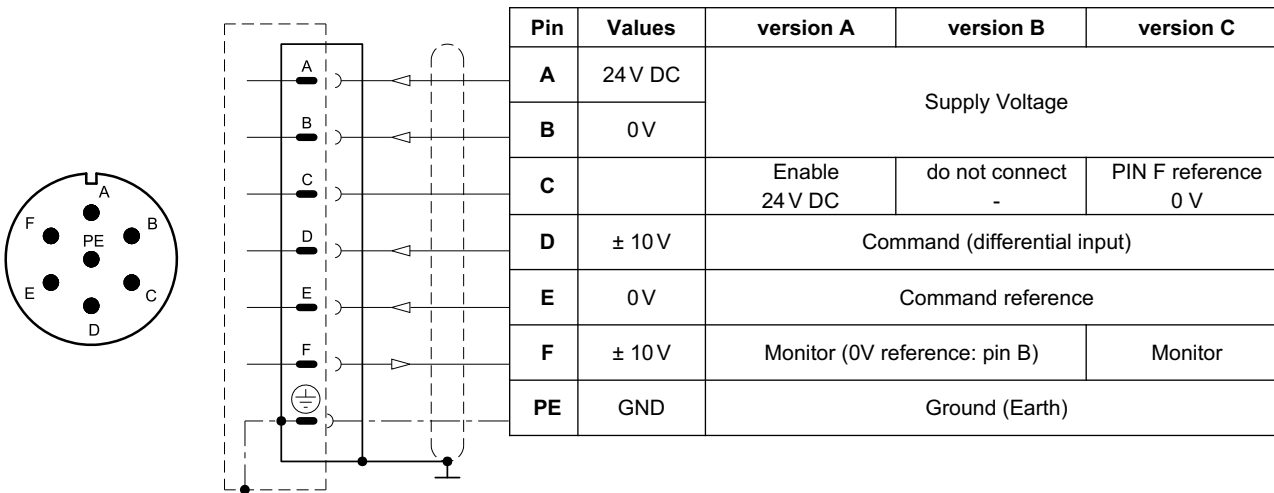
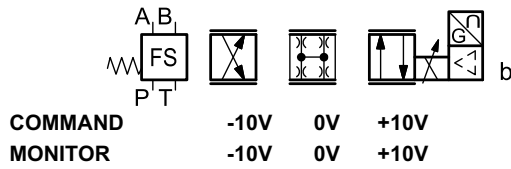

4.4 - Versions with CURRENT COMMAND (E1)

The reference signal is supplied in current 4 + 20 mA. If the current for command is lower, the card shows a breakdown cable error. To reset the error is sufficient to restore the signal.

The monitor feature of versions B and C becomes available with a delay of 0,5 sec from the power-on of the card.

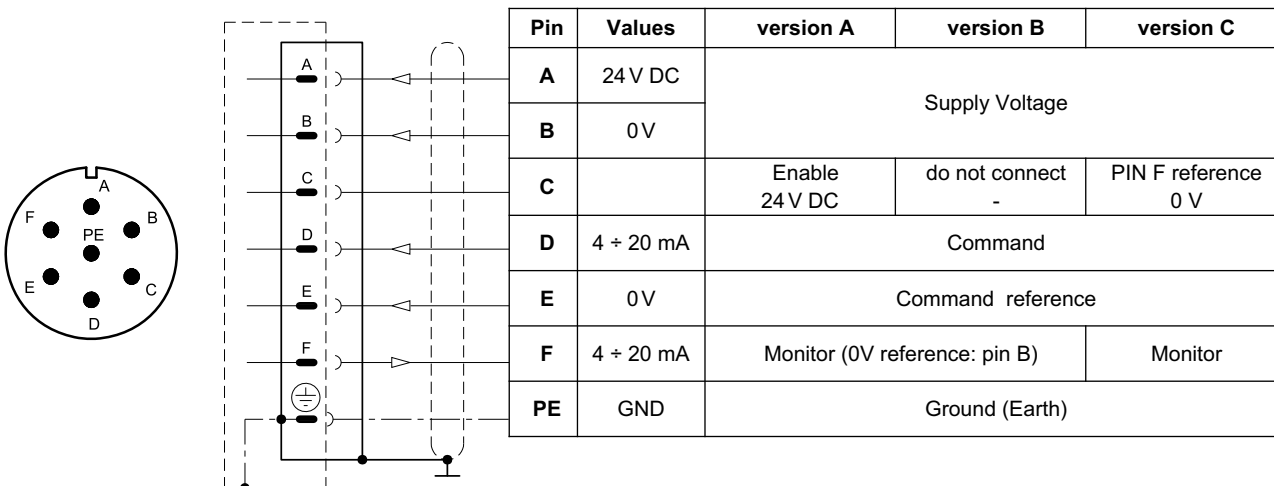
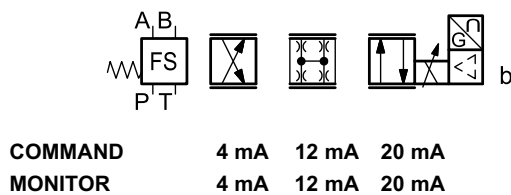

5 - DXE5JH - FIELDBUS ELECTRONICS

The 11+ PE pin connection allows separate supply voltage for electronics and solenoids.

Command - valve position schemes as for the standard electronics. Please refer to pictures in par. 4.3 and 4.4.

5.1 - Electrical characteristics

Command signal:	voltage (E0) current (E1) digital (FD)	V DC mA	±10 (Impedance Ri = 11 kOhm) 4 ÷ 20 (Impedance Ri = 58 Ohm) via fieldbus
Monitor signal (current to solenoid):	voltage (E0) current (E1)	V DC mA	±10 (Impedance Ro > 1 kOhm) 4 ÷ 20 (Impedance Ro = 500 Ohm)
Communication / diagnostic			via Bus register
Communication interface standards PROFIBUS DP EtherCAT, Ethernet /IP, Profinet, PowerLink			EN 50170-2 / IEC 61158 IEC 61158
Communication physical layer PROFIBUS DP EtherCAT, Ethernet /IP, Profinet, PowerLink			optical insulated RS485 fast ethernet, insulated 100 Base TX
Power connection			11 pin + PE (DIN 43651)

5.2 - X1 Main connection pin table

D1: one command

Pin	Values	Function
1	24V DC	Main supply voltage
2	0V	
3	24V DC	Enable
4	± 10V (E0) 4 ÷ 20 (E1)	Command
5	0V	Command reference signal
6	± 10V (E0) 4 ÷ 20 (E1)	Monitor (0V reference pin 10)
7	NC	do not connect
8	NC	do not connect
9	24V DC	Logic and control supply
10	0V	
11	24V DC	Fault (0V DC) or normal working (24V DC) (0V reference pin 2)
12	GND	Ground (Earth)

D0: full digital

Pin	Values	Function
1	24V DC	Main supply voltage
2	0V	
3	24V DC	Enable
4	NC	do not connect
5	NC	do not connect
6	NC	do not connect
7	NC	do not connect
8	NC	do not connect
9	24V DC	Logic and control supply
10	0V	
11	24V DC	Fault (0V DC) or normal working (24V DC) (0V ref. pin 2)
12	GND	Ground (Earth)

5.3 - FIELDBUS connections

Please wire following guidelines provided by the relative standards communication protocol.

Any connections present and not used must be protected with special caps so as not to nullify the protection against atmospheric agents.

5.3.1 - Communication connection PD (PROFIBUS DP)

X2 (IN) connection: M12 B 5 pin male (IN)



Pin	Values	Function
1	+5 V	Termination supply signal
2	PB_A	Bus line (high)
3	0V	Data line and termination signal 0
4	PB_B	Bus line (low)
5	SHIELD	

X3 (OUT) connection: M12 B 5 pin female



Pin	Values	Function
1	+5V	Termination supply signal
2	PB_A	Bus line (high)
3	0V	Data line and termination signal 0
4	PB_B	Bus line (low)
5	SHIELD	

5.3.2 - Communication connections: EC (EtherCat), EN (Ethernet/IP), PN (PROFINET), PL (POWERLINK)

X2 (IN) connection M12 D 4 pin female



Pin	Values	Function
1	TX+	Transmitter
2	RX+	Receiver
3	TX-	Transmitter
4	RX-	Receiver
HOUSING	shield	

X3 (OUT) connection: M12 D 4 pin female



Pin	Values	Function
1	TX+	Transmitter
2	RX+	Receiver
3	TX-	Transmitter
4	RX-	Receiver
HOUSING	shield	

NOTE: Shield connection on connector housing is recommended.

5.4 - Digital transducer connection

X7 connection: M12 A 8 pin female

VERSION 1: SSI type

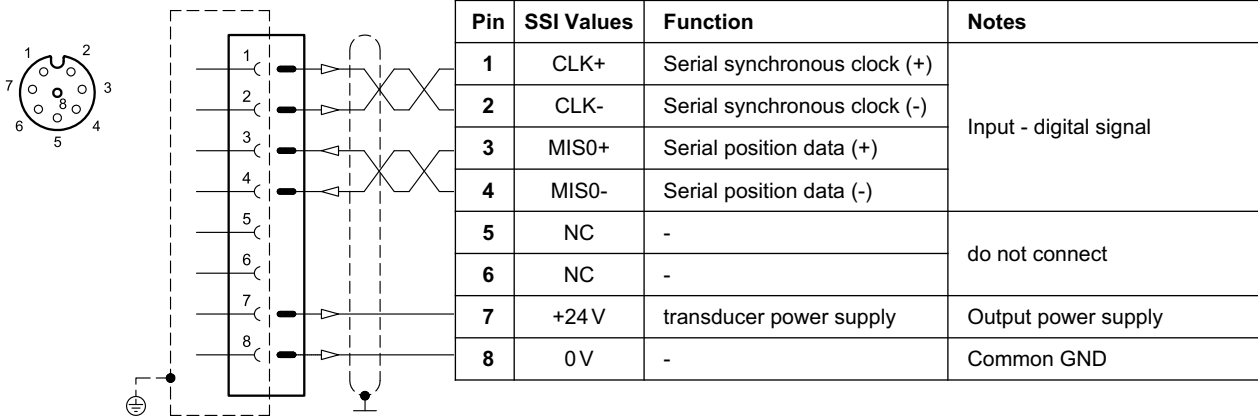

VERSION 2: ENCODER type

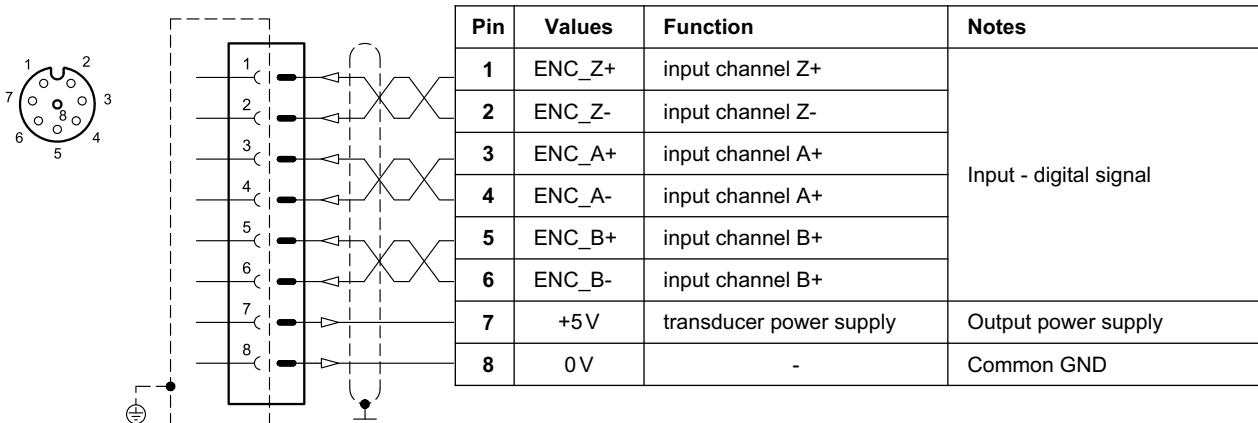

5.5 - Analogue transducer connection

X4 connection: M12 A 4 pin female

VERSION 1: single / double transducer

(single or double is a software-selectable option)

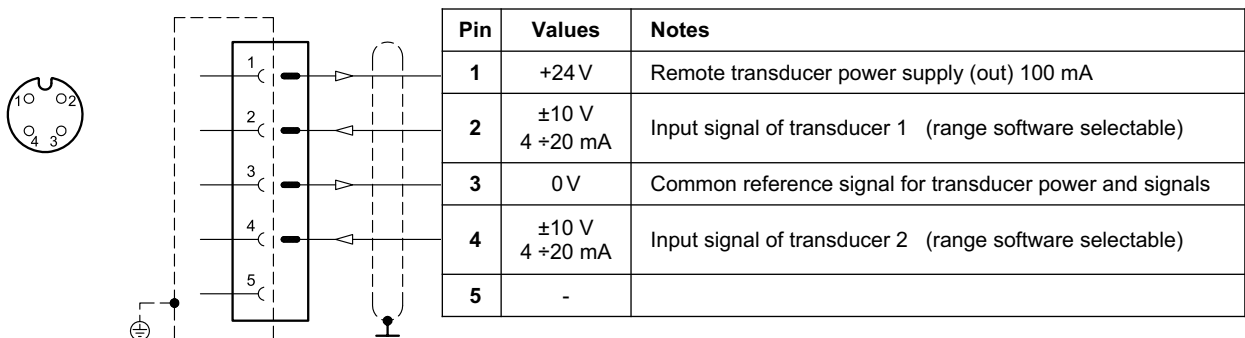

6 - CHARACTERISTIC CURVES

(measured with viscosity of 36 cSt at 50°C)

REFERENCE / FLOW RATE CURVE

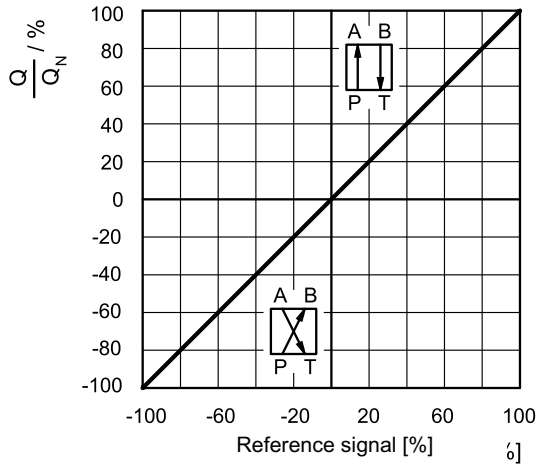

FLOW RATE CURVE ACCORDING TO Δp

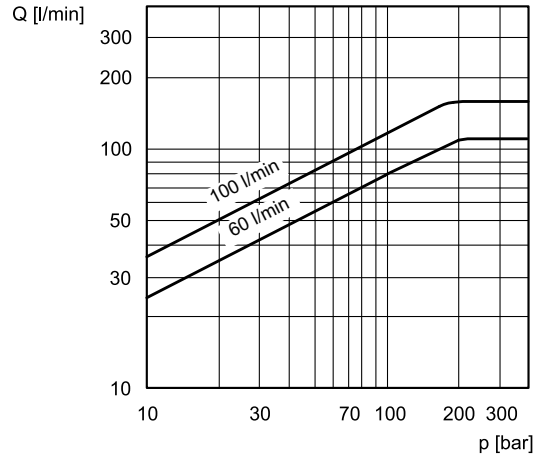

Typical flow rate curves at constant $\Delta p = 70$ bar P-T according to the reference signal.

NOTE: with positive reference signal connected to pin D the valve regulates P - A / B - T.

The diagram states the maximum valve controlled flow rate according to the pressure drop between the P and T ports.

PRESSURE GAIN

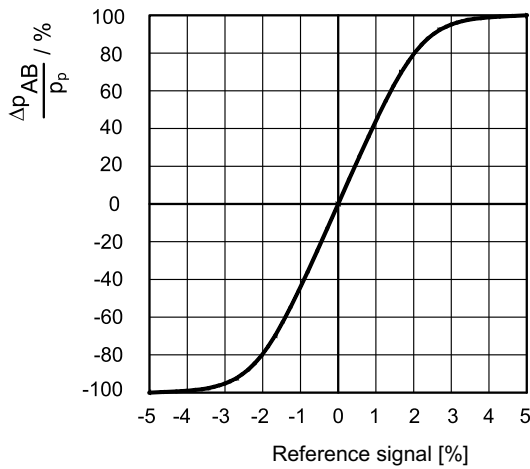

The diagram shows the valve pressure gain, expressed as % of the ratio between the port pressure variation in A or B (Δp_{AB}) and the P system pressure, according to the reference signal. In practice, the pressure gain states the valve reaction towards external disturbances aimed at changing the actuator position.

RESPONSE TIME

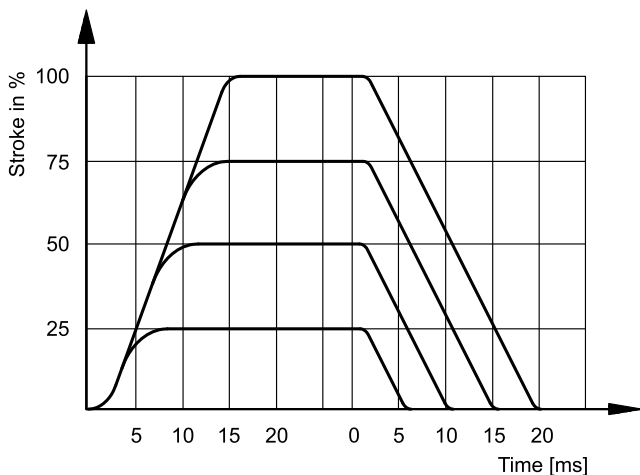

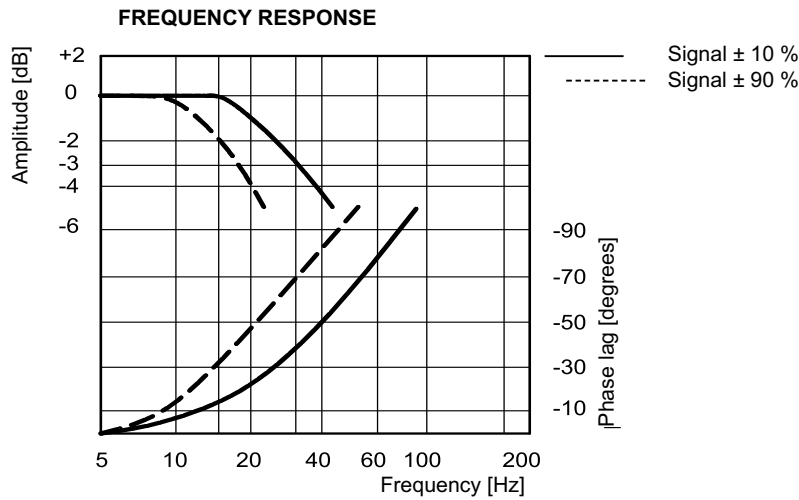

7 - DXE5J - OVERALL AND MOUNTING DIMENSIONS

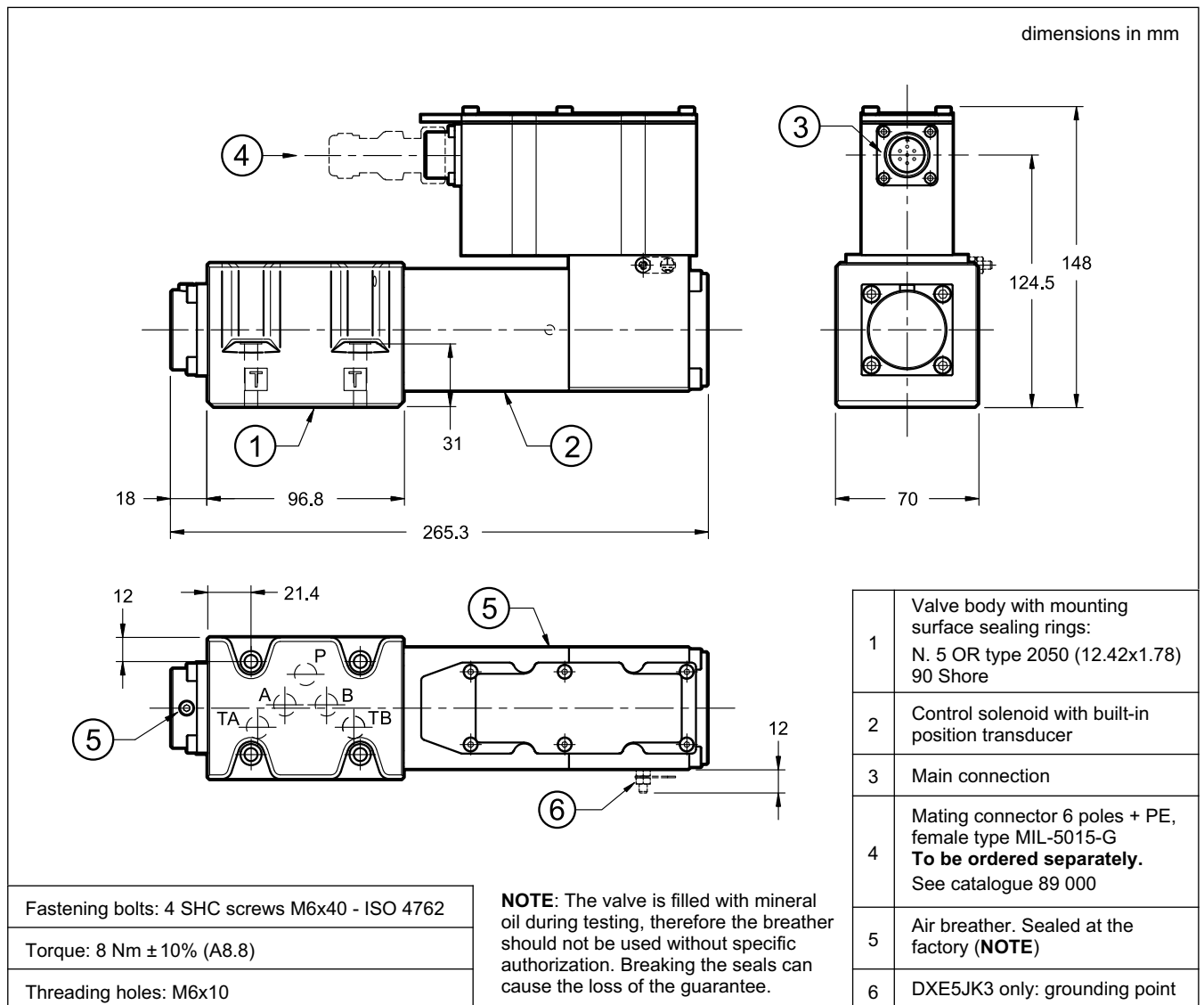

8 - DXE5JH - OVERALL AND MOUNTING DIMENSIONS

dimensions in mm

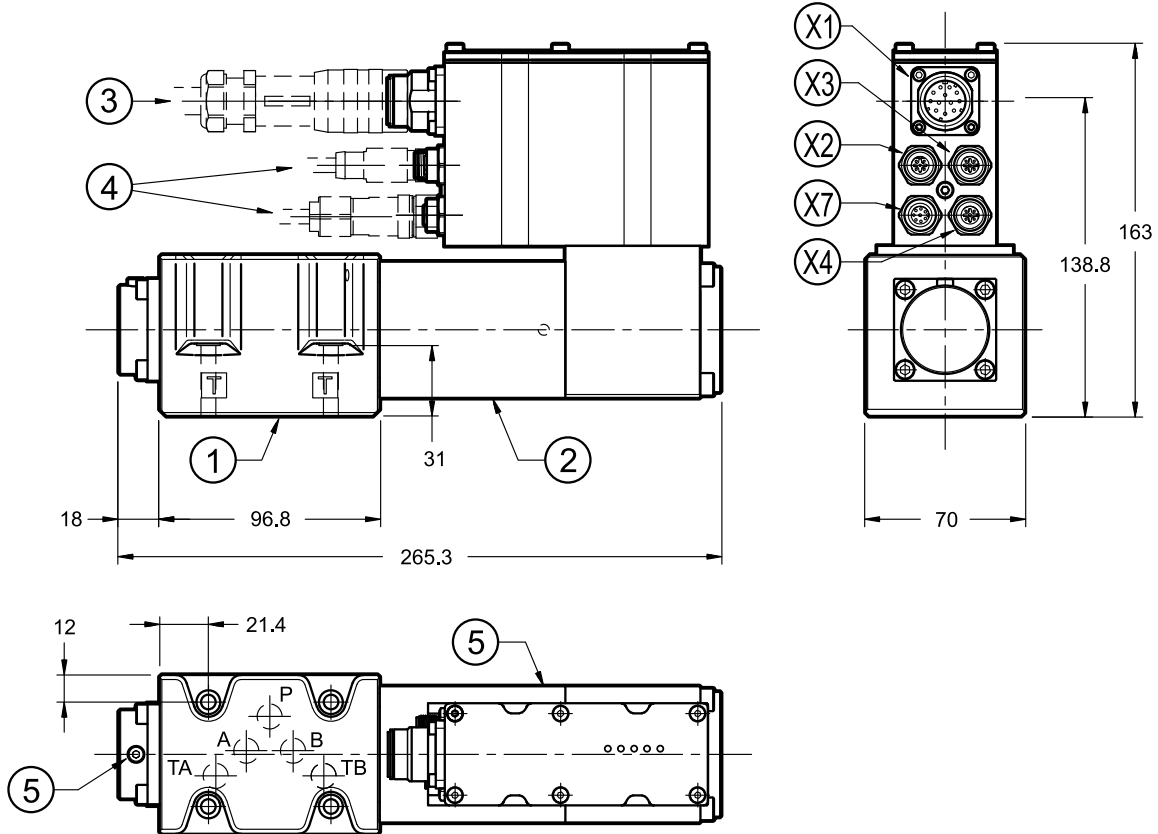

X1	Main connection 11 pin + PE
X2	Fieldbus communication (IN)
X3	Fieldbus communication (OUT)
X4	X4 connection for analogue transducer
X7	X7 connection for digital transducer

1	Mounting surface with sealing rings: N. 5 OR type 2050 (12.42x1.78) 90 Shore
2	Control solenoid with built-in position transducer
3	Mating connector 11 poles + PE To be ordered separately. See catalogue 89 000
4	Mating connectors for fieldbus communication and signals To be ordered separately. See catalogue 89 000
5	Air breather. Sealed at the factory (NOTE 2)

NOTE 1: Depending on the chosen version, X4 and X7 connections may not be present.
Please refer to section 5 for connection descriptions and pinout.

NOTE 2: The valve is filled with mineral oil during testing, therefore the breather should not be used without specific authorization. Breaking the seals can cause the loss of the guarantee.

Fastening bolts: 4 bolts M6x40 - ISO 4762

Torque: 8 Nm \pm 10% (A8.8)

Threading holes: M6x10

9 - HYDRAULIC FLUIDS

Use mineral oil-based hydraulic fluids HL or HM type, according to ISO 6743-4. For these fluids, use NBR seals. For fluids HFDR type (phosphate esters) use FPM seals (code V). For the use of other kinds of fluid such as HFA, HFB, HFC, please consult our technical department.

Using fluids at temperatures higher than 80 °C causes a faster degradation of the fluid and of the seals characteristics.

The fluid must be preserved in its physical and chemical characteristics.

10 - INSTALLATION

The valves can be installed in any position without impairing correct operation. Valves are fixed by means of screws or tie rods on a flat surface with planarity and roughness equal to or better than those indicated in the relative symbols.

If minimum values are not observed, fluid can easily leaks between the valve and support surface.

Take care to the cleanliness of the mounting surfaces and surrounding environment upon installation.

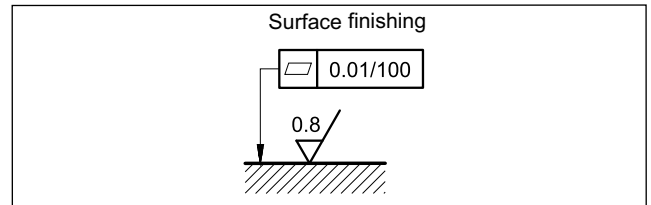

11 - ACCESSORIES

(to be ordered separately)

11.1 - Mating connectors

Mating connectors must be ordered separately. See catalogue 89 000.



We recommend the choice of a metal connector to avoid electromagnetic disturbances and to comply with EMC regulations on electromagnetic compatibility. If you opt for a plastic connector, make sure that it guarantees and maintains the IP and EMC protection characteristics of the valve.

11.2 - Mating connectors and caps for fieldbus communication and for sensors.

Duplomatic offers spare parts to be wired and also ready-to-use cord sets. Please refer to cat. 89 000.

11.3 - Connection cable

The optimal wiring provides for 7 isolated conductors, with separate screen for the signal wires (command, monitor) and an overall screen.

Cross section for power supply:

- up to 20 m cable length : 1,0 mm²
- up to 40 m cable length : 1,5 mm²

Cross section for signals (command, monitor):

- 0,50 mm²

11.4 - Kit for start-up LINPC-USB

Device for service start-up and diagnostic. See catalogue 89 850.

12 - SUBPLATES

(see catalogue 51 000)

PMD4-AI4G rear ports 3/4" BSP
PMD4-AL4G side ports 1/2" BSP



DXE5J

SERIES 31



DIPLOMATIC MS S.p.A.

via M. Re Depaulini 24 • 20015 PARABIAGO (MI) • ITALY
tel. +39 0331.895.111 • www.diplomatic.com • e-mail: sales.exp@diplomatic.com