

ZDE3G*

DIRECT OPERATED PRESSURE REDUCING VALVE WITH PROPORTIONAL CONTROL AND INTEGRATED ELECTRONICS

SERIES 32

**SUBPLATE MOUNTING
ISO 4401-03**

**p max 100 bar
Q max 15 l/min**

MOUNTING INTERFACE

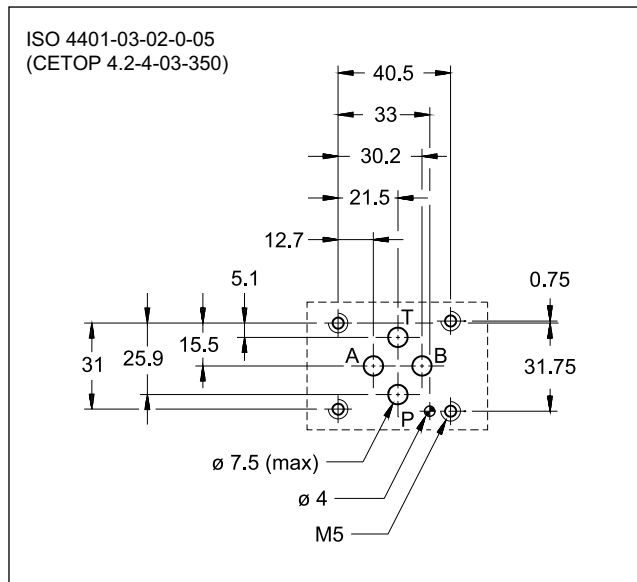

OPERATING PRINCIPLE

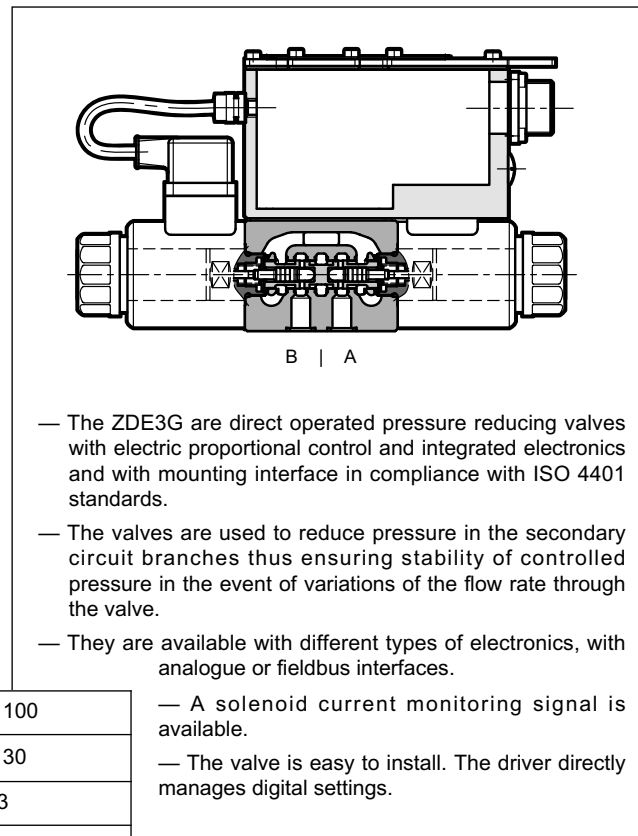

PERFORMANCES

(obtained with mineral oil with viscosity of 36 cSt at 50°C and p = 140 bar)

Operating pressure range port P	bar	30 ÷ 100
Operating pressure range port T (par. 5)	bar	0 ÷ 30
Controlled pressure	bar	23
Maximum flow	l/min	15
Hysteresis	% Q max	< 3 %
Repeatability	% Q max	< 1 %
Electrical characteristics	see paragraph 2	
Ambient temperature range	°C	-20 / +50
Fluid temperature range	°C	-20 / +80
Fluid viscosity range	cSt	10 ÷ 400
Fluid contamination degree	According to ISO 4406:1999 class 18/16/13	
Recommended viscosity	cSt	25
Mass: single solenoid valve	kg	1,9
double solenoid valve	kg	2,4

HYDRAULIC SYMBOL

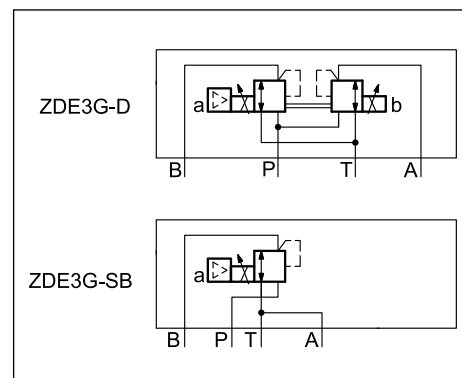



1 - IDENTIFICATION CODE

1.1 - Standard

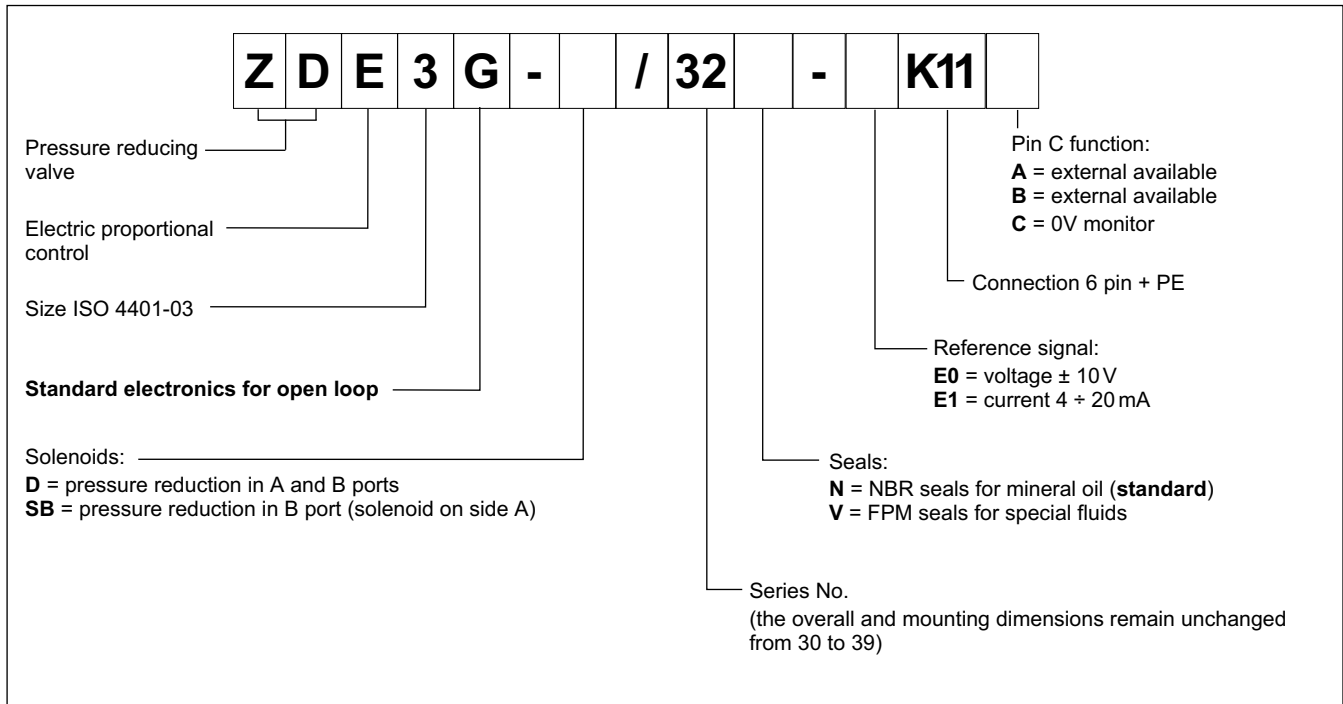

1.2 - Compact version

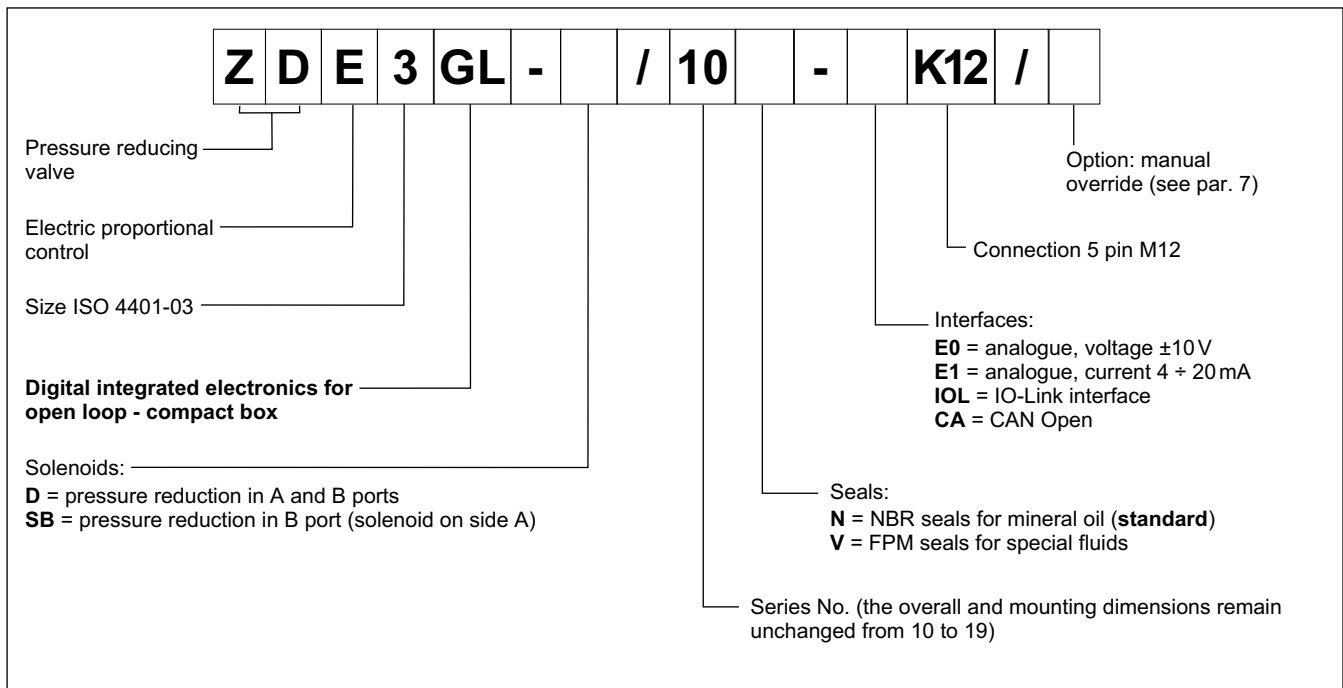



1.3 - Electronics with fieldbus communication

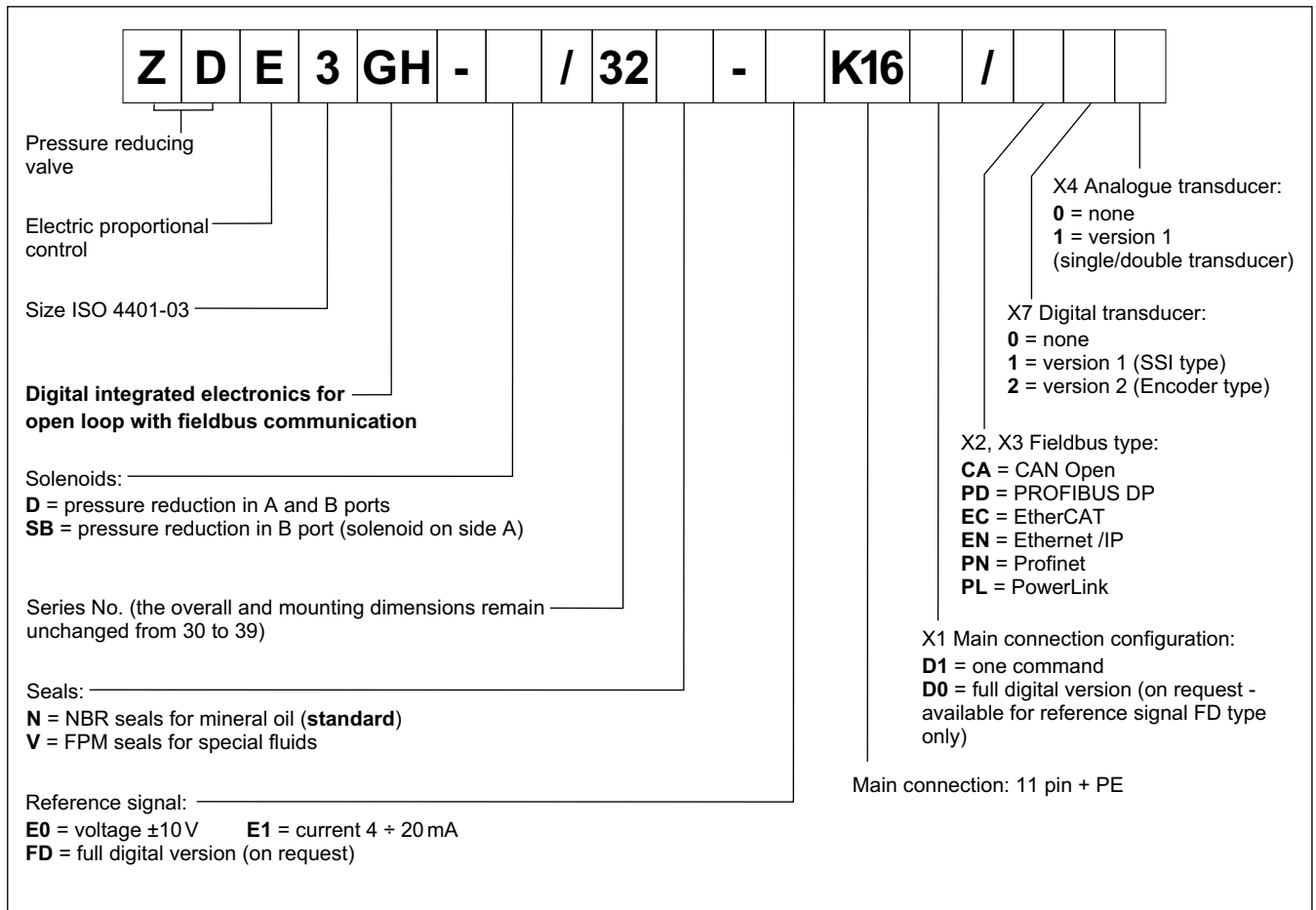



2 - ELECTRONICS COMMON DATA

Duty cycle		100% (continuous operation)
Protection class according to EN 60529		IP65 / IP67
Supply voltage	V DC	24 (from 19 to 30 VDC), ripple max 3 Vpp
Power consumption	VA	25
Maximum solenoid current	A	1.88
Fuse protection, external	A	3
Managed breakdowns		Overload and electronics overheating, cable breakdown, supply voltage failures
Electromagnetic compatibility (EMC) emissions EN 61000-6-4, immunity EN 61000-6-2		According to 2014/30/EU standards

3 - ZDE3G - STANDARD ELECTRONICS

3.1 - Electrical characteristics

Command signal:	voltage (E0) current (E1)	V DC mA	± 10 (Impedance $R_i = 11 \text{ k}\Omega$) $4 \div 20$ (Impedance $R_i = 58 \text{ }\Omega$)
Monitor signal (current to solenoid):	voltage (E0) current (E1)	V DC mA	± 10 (Impedance $R_o > 1 \text{ k}\Omega$) $4 \div 20$ (Impedance $R_o = 500 \text{ }\Omega$)
Communication for diagnostic			LIN-bus Interface (by means of the optional kit)
Connection			6 pin + PE (MIL-C-5015-G - DIN EN 175201-804)

3.2 - On-board electronics diagrams

VERSION A - External Enable

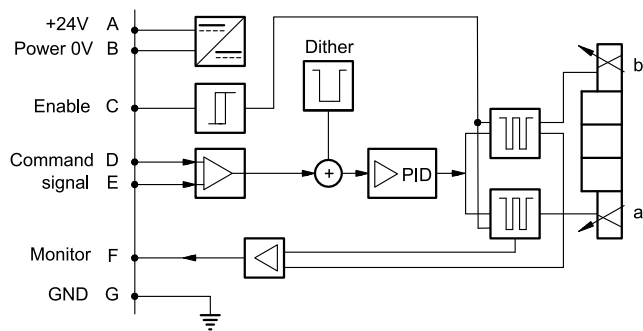

VERSION B - Internal Enable

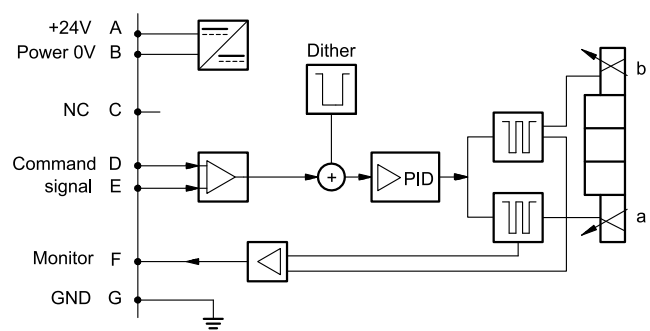

VERSION C - 0V Monitor

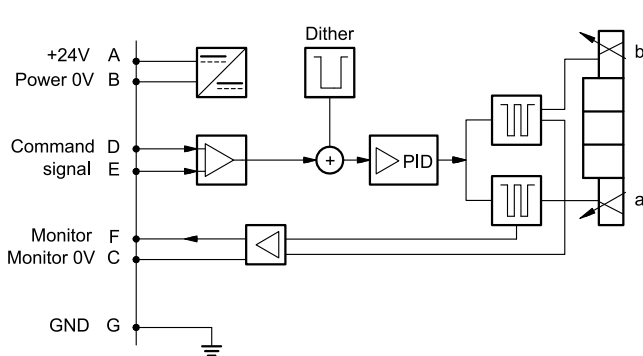

3.3 - Versions with voltage command (E0)

The reference signal is between -10V and +10V on double solenoid valve, and 0 + 10V on single solenoid valve SA. The monitor feature of versions B and C becomes available with a delay of 0,5 sec from the power-on of the card.

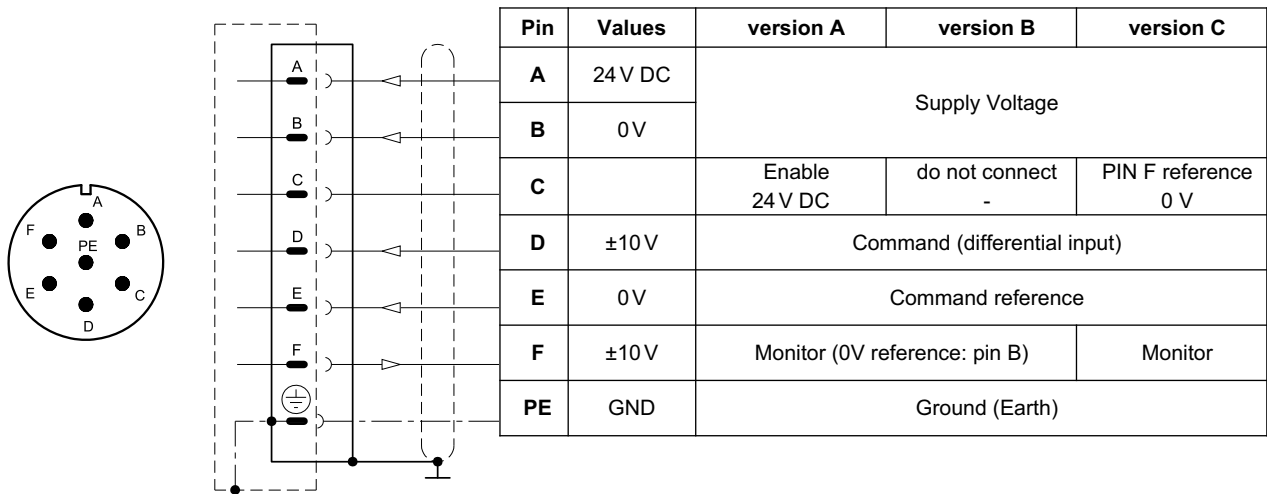
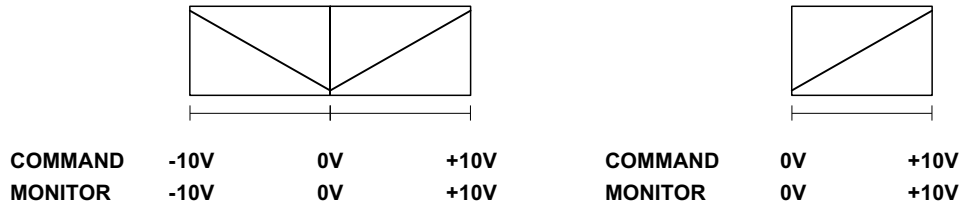

3.4 - Versions with current command (E1)

The reference signal is supplied in current $4 \div 20$ mA. If the current for command is lower, the card shows a breakdown cable error. To reset the error is sufficient restoring the signal.

The monitor feature of versions B and C becomes available with a delay of 0,5 sec from the power-on of the card.

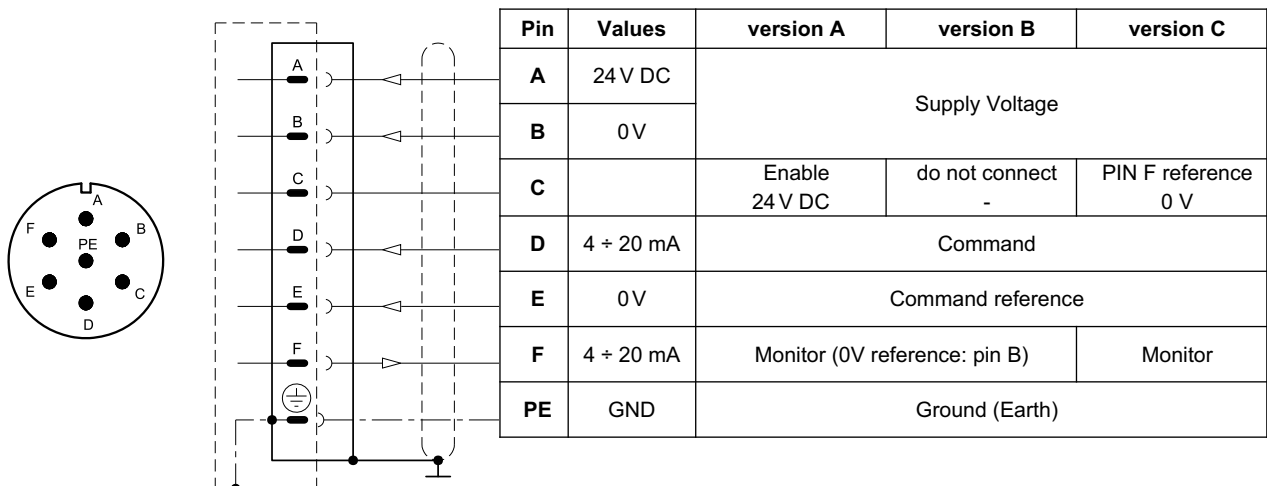
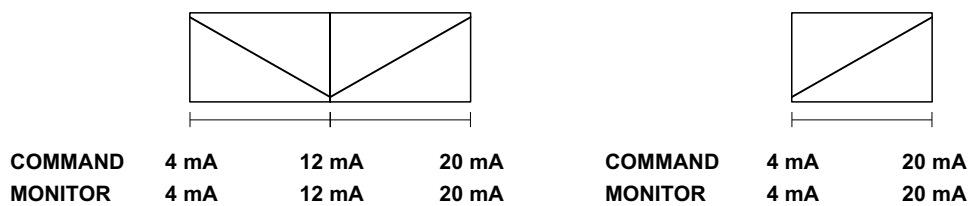

4 - ZDE3GL - COMPACT ELECTRONICS

In versions 'IOL' and 'CA' pin 3 and pin 5 are galvanic isolated up to 100 V to avoid earth loops. In IO-Link networks, the length of the connecting cables is limited to 20 metres.

4.1 - Electrical characteristics

Command signal: voltage (E0) current (E1)	V DC mA	± 10 (Impedance $R_i = 11 \text{ k}\Omega$) $4 \div 20$ (Impedance $R_i = 58 \text{ }\Omega$)
Monitor signal (current to solenoid): voltage (E0) current (E1)	V DC mA	$0 \div 5$ (Impedance $R_o > 1 \text{ k}\Omega$) $4 \div 20$ (Impedance $R_o = 500 \text{ }\Omega$)
IO-Link communication (IOL): Data rate	kBaud	IO-Link Port Class B 230,4
Can Open communication (CA): Data rate	kbit	$10 \div 1000$
Connection		5-pin M12 code A (IEC 61076-2-101)

4.2 - Pin tables

'E0' connection

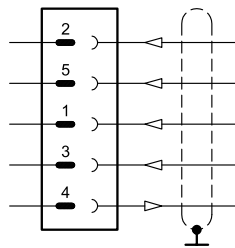

Pin	Values	Function
2	24 V DC	Supply voltage (solenoid and logic)
5	0V	
1	$\pm 10\text{V}$	Command
3	0V	Command reference
4	$0 \div 5\text{V}$	Monitor (0V reference: pin 5)

'E1' connection

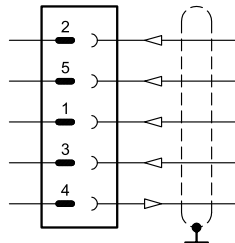

Pin	Values	Function
2	24 V DC	Supply voltage (solenoid and logic)
5	0V	
1	$4 \div 20 \text{ mA}$	Command
3	0V	Command reference
4	$4 \div 20 \text{ mA}$	Monitor (0V reference: pin 5)

'IOL' connection

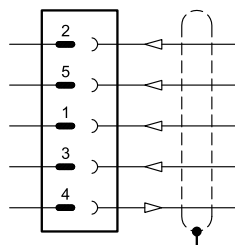

Pin	Values	Function
2	2L+ 24 V DC	Supply of the power stage
5	2L- 0V (GND)	Internal galvanic isolation from PIN 3
1	1L+ +24 V DC	IO-Link supply voltage
3	1L- 0V (GND)	
4	C/Q	IO-Link Communication

'CA' connection

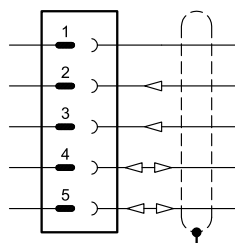

Pin	Values	Function
1	CAN_SH	Shield
2	24 V DC	Supply voltage
3	0V (GND)	
4	CAN H	Bus line (high)
5	CAN_L	Bus line (low)

5 - ZDE3GH - FIELDBUS ELECTRONICS

The 11+ PE pin connection allows separate supply voltage for electronics and solenoids.

Command - valve position schemes as for the standard electronics. Please refer to pictures in par. 3.3 and 3.4.

5.1 - Electrical characteristics

Command signal: voltage (E0) current (E1) digital (FD)	V DC mA	± 10 (Impedance $R_i = 11 \text{ k}\Omega$) $4 \div 20$ (Impedance $R_i = 58 \text{ }\Omega$) via fieldbus
Monitor signal (current to solenoid): voltage (E0) current (E1)	V DC mA	± 10 (Impedance $R_o > 1 \text{ k}\Omega$) $4 \div 20$ (Impedance $R_o = 500 \text{ }\Omega$)
Communication / diagnostic		via Bus register
Communication interface standards CAN Open PROFIBUS DP EtherCAT, Ethernet /IP, Profinet, PowerLink		EN 50325-4 + DS408 EN 50170-2 / IEC 61158 IEC 61158
Communication physical layer CAN Open PROFIBUS DP EtherCAT, Ethernet /IP, Profinet, PowerLink		optical insulated CAN ISO 11898 optical insulated RS485 fast ethernet, insulated 100 Base TX
Power connection		11 pin + PE (DIN 43651)

5.2 - X1 Main connection pin table

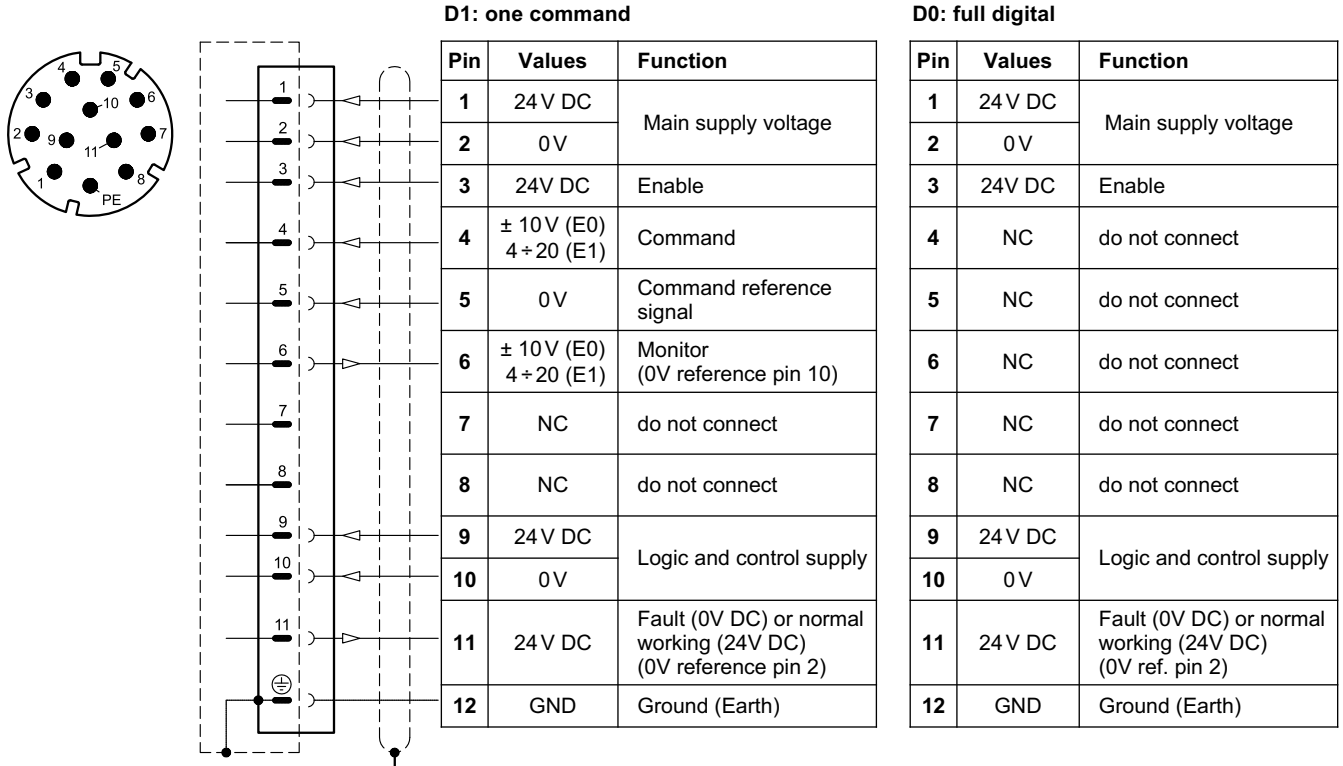

5.3 - FIELDBUS connections

Please wire following guidelines provided by the relative standards communication protocol.

5.3.1 - Communication connection CA (CAN Open)

X2 (IN) connection: M12 A 5 pin female



Pin	Values	Function
1	CAN_SH	Shield
2	NC	Do not connect
3	GND	Signal zero data line
4	CAN_H	Bus line (high)
5	CAN_L	Bus line (low)

X3 (OUT) connection: M12 A 5 pin male



Pin	Values	Function
1	CAN_SH	Shield
2	NC	Do not connect
3	GND	Signal zero data line
4	CAN_H	Bus line (high)
5	CAN_L	Bus line (low)

5.3.2 - Communication connection PD (PROFIBUS DP)

X2 (IN) connection: M12 B 5 pin male (IN)



Pin	Values	Function
1	+5 V	Termination supply signal
2	PB_A	Bus line (high)
3	0V	Data line and termination signal 0
4	PB_B	Bus line (low)
5	SHIELD	

X3 (OUT) connection: M12 B 5 pin female



Pin	Values	Function
1	+5 V	Termination supply signal
2	PB_A	Bus line (high)
3	0V	Data line and termination signal 0
4	PB_B	Bus line (low)
5	SHIELD	

5.3.3 - Communication connections: EC (EtherCat), EN (Ethernet/IP), PN (PROFINET), PL (POWERLINK)

X2 (IN) connection: M12 D 4 pin female



Pin	Values	Function
1	TX+	Transmitter
2	RX+	Receiver
3	TX-	Transmitter
4	RX-	Receiver
HOUSING	shield	

X3 (OUT) connection: M12 D 4 pin female



Pin	Values	Function
1	TX+	Transmitter
2	RX+	Receiver
3	TX-	Transmitter
4	RX-	Receiver
HOUSING	shield	

NOTE: Shield connection on connector housing is recommended.

5.4 - Digital transducer connection

X7 connection: M12 A 8 pin female

VERSION 1: SSI type

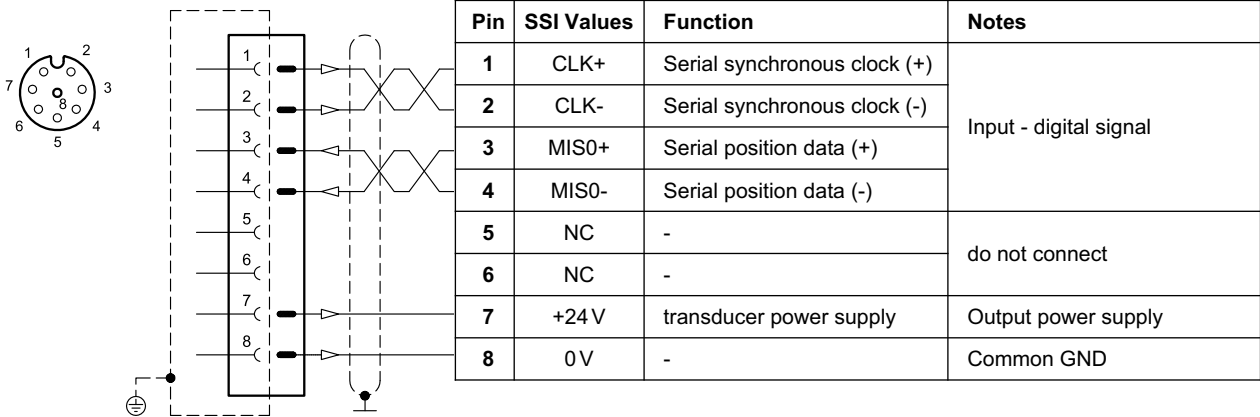

VERSION 2: ENCODER type

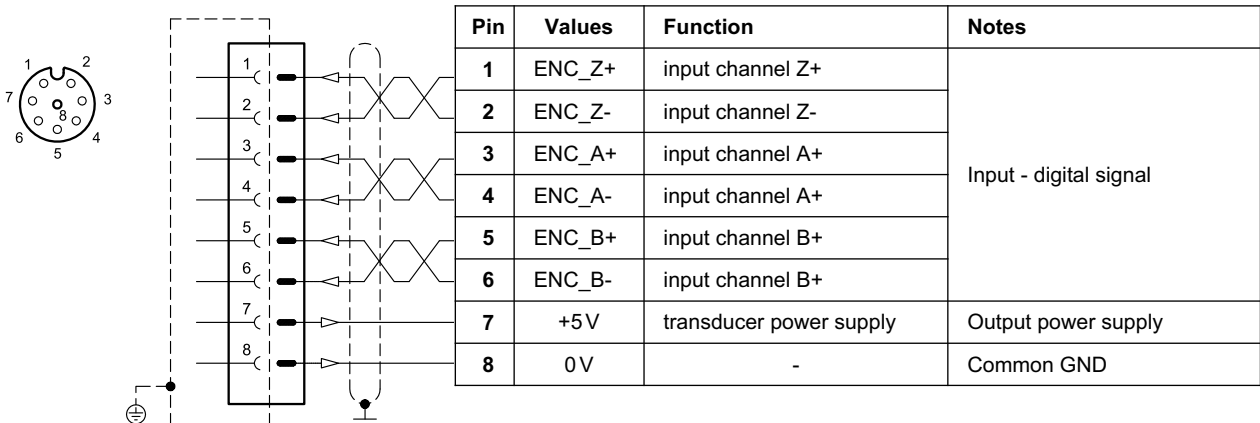

5.5 - Analogue transducer connection

X4 connection: M12 A 4 pin female

VERSION 1: single / double transducer

(single or double is a software-selectable option)

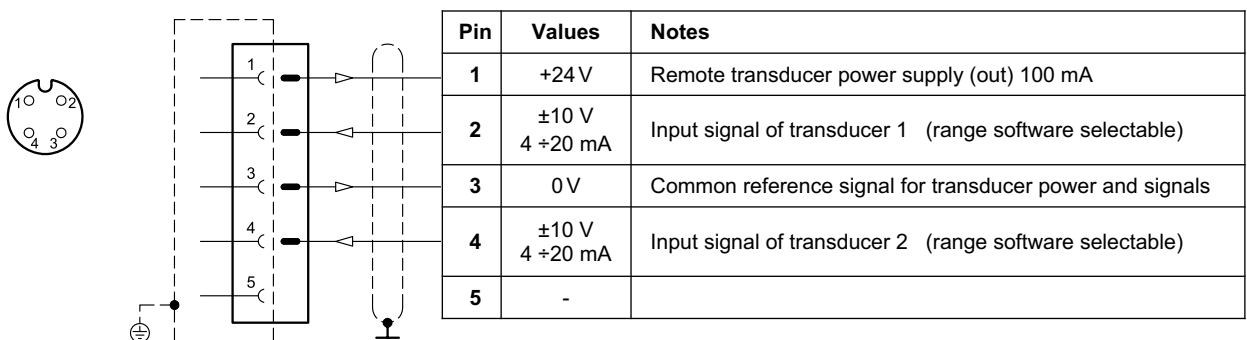



6 - CHARACTERISTIC CURVES

(obtained with oil with viscosity 36 cSt at 50°C)

Adjustment characteristics depending from reference signal, obtained with inlet pressure = 100 bar.

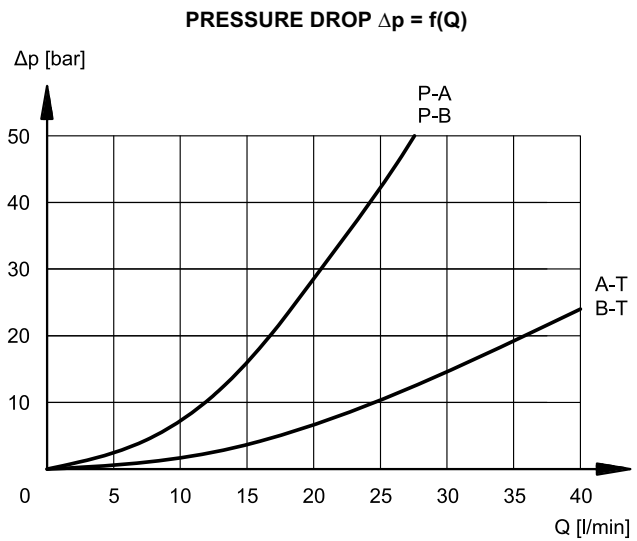
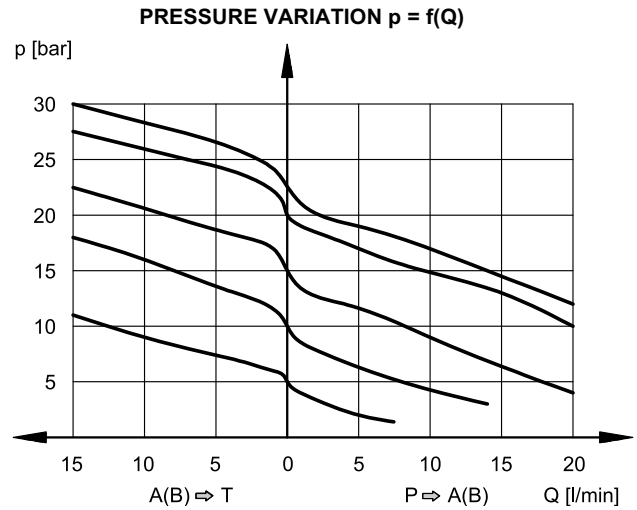
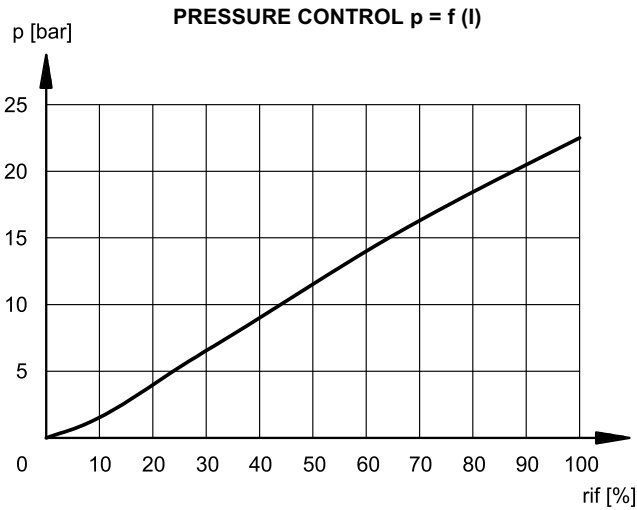

7 - STEP RESPONSE

Response times are obtained with an inlet pressure of 100 bar and oil volume of 0,3 litres. The response time is affected both by the flow rate and the oil volume in the pipework.

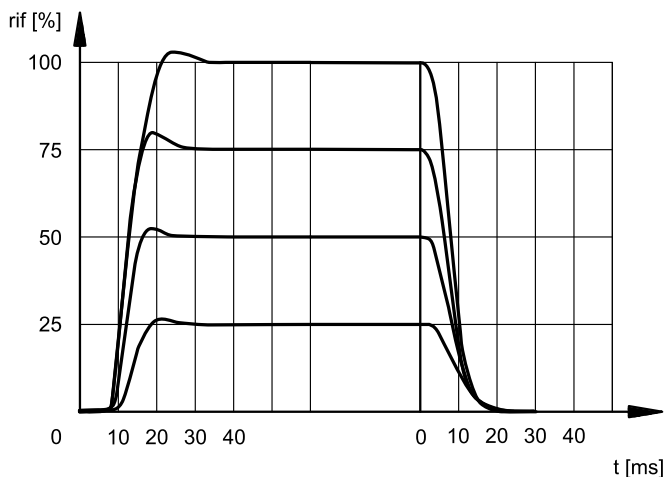

8 - ZDE3G - OVERALL AND MOUNTING DIMENSIONS

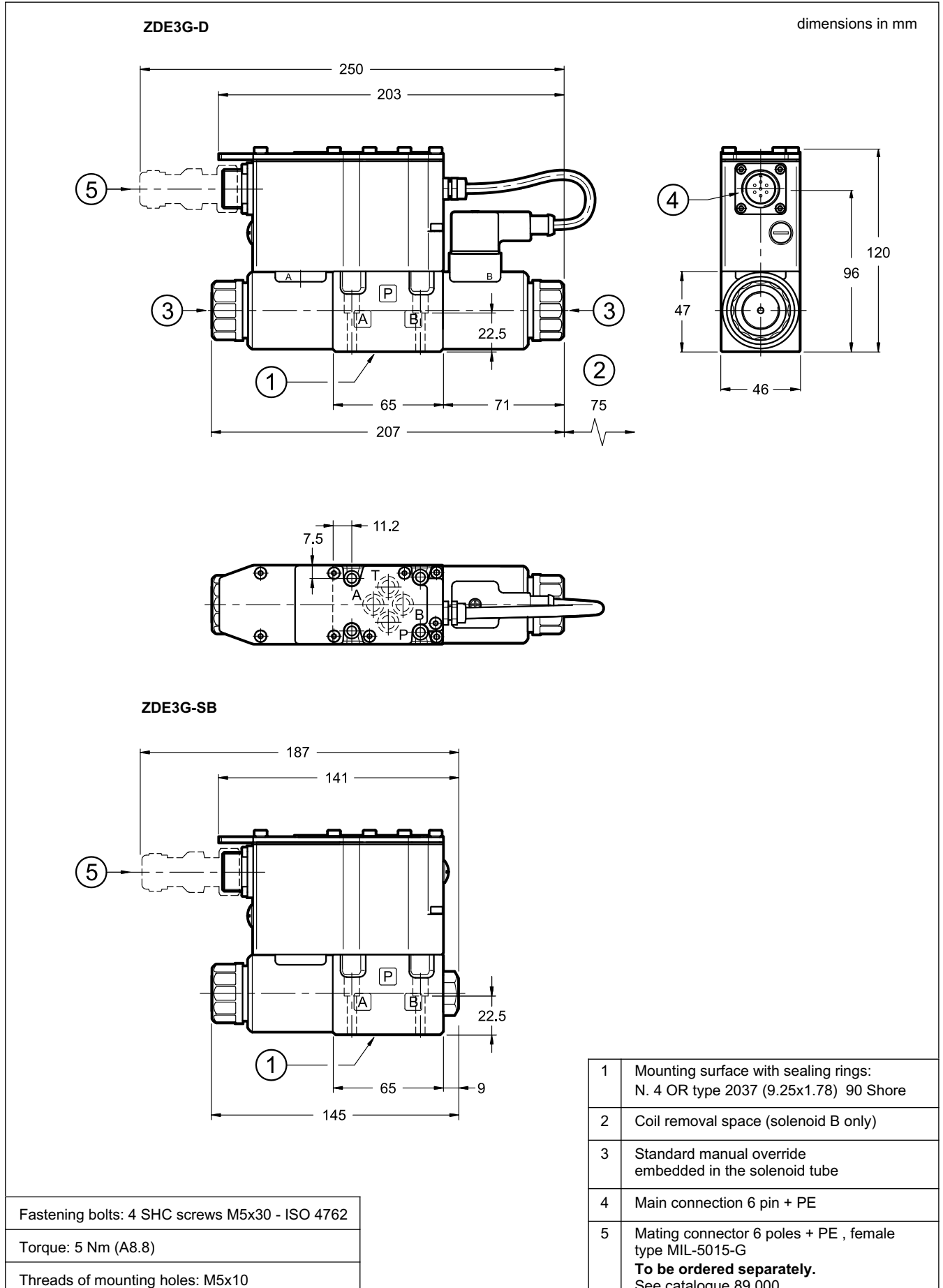

9 - ZDE3GL - OVERALL AND MOUNTING DIMENSIONS

ZDE3GL-*/K12

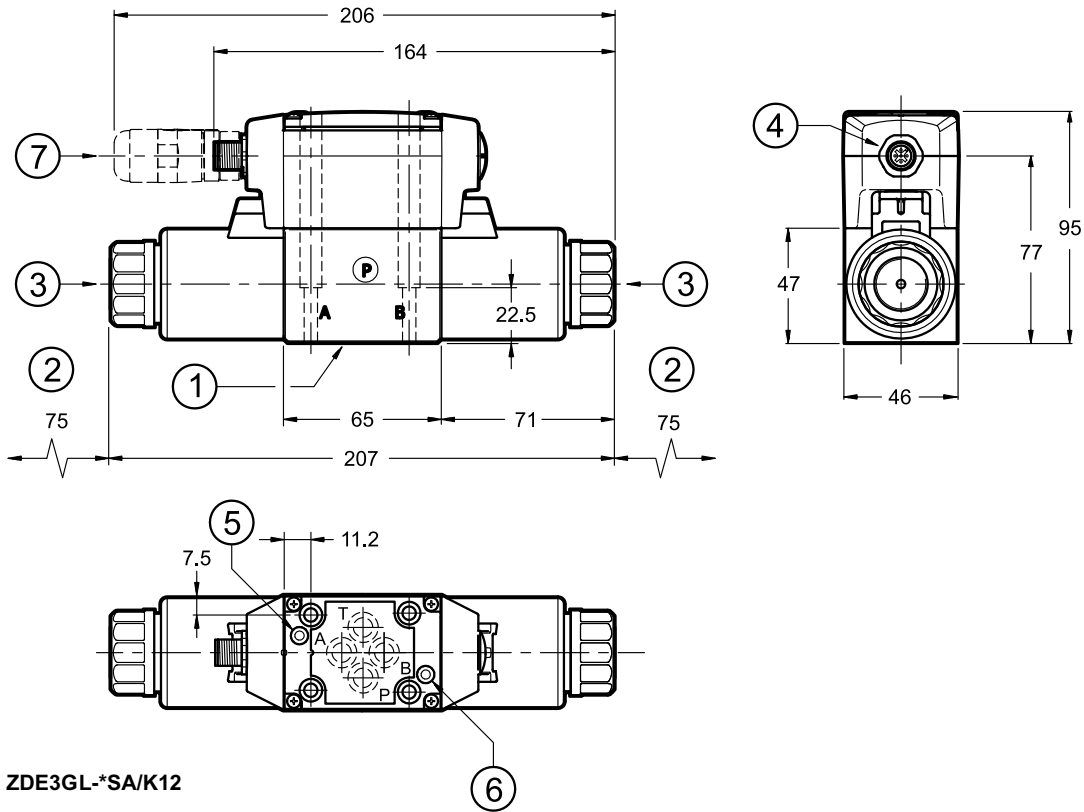

ZDE3GL-*/SA/K12

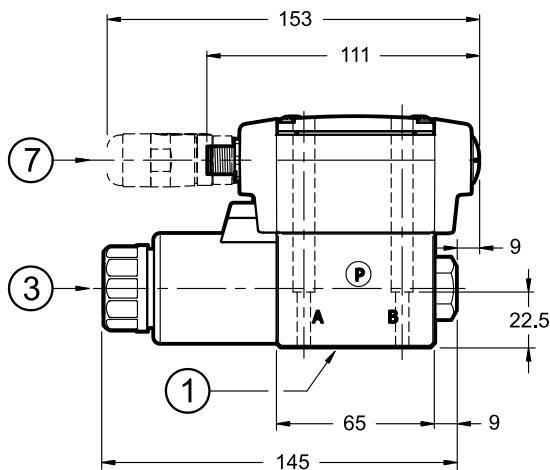

Fastening bolts: 4 SHC screws M5x30- ISO 4762

Torque: 5 Nm (A8.8)

Threads of mounting holes: M5x10

1	Mounting surface with sealing rings: N. 4 OR type 2037 (9.25x1.78) 90 Shore
2	Coil removal space
3	Standard manual override embedded in the solenoid tube
4	Connection M12 A 5 pin
5	L1 LED
6	L2 LED
7	Mating connector M12 5 poles - code A, female To be ordered separately. See catalogue 89 000

10 - ZDE3GH - OVERALL AND MOUNTING DIMENSIONS

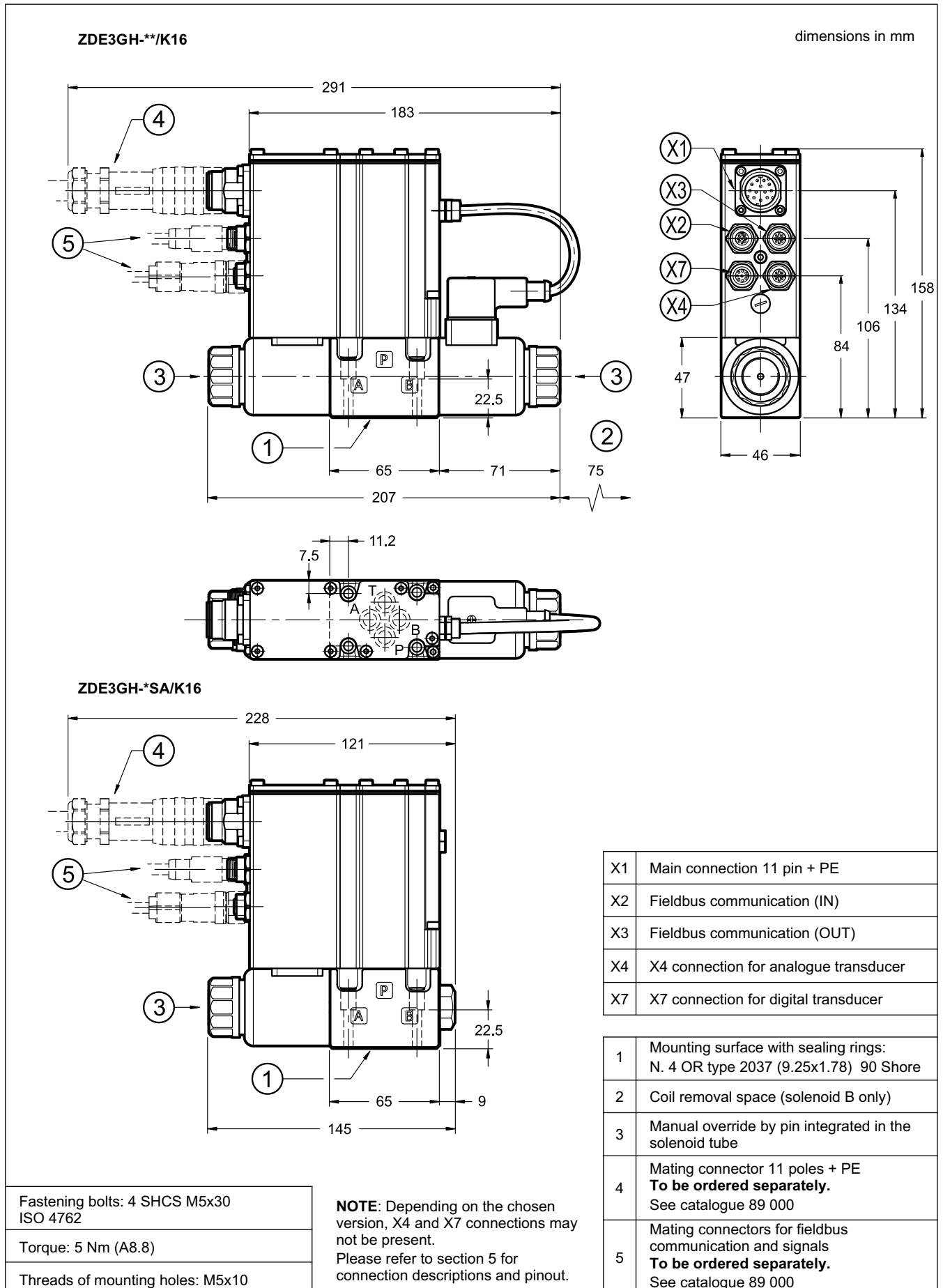

Fastening bolts: 4 SHCS M5x30
ISO 4762

Torque: 5 Nm (A8.8)

Threads of mounting holes: M5x10

NOTE: Depending on the chosen version, X4 and X7 connections may not be present. Please refer to section 5 for connection descriptions and pinout.



11 - MANUAL OVERRIDE

These valves have solenoids whose pin for manual operation is integrated in the tube. Actuate this override by pushing it with a suitable tool, minding not to damage the sliding surface.

Three other types of manual overrides can fit the ZDE3GL valve:

- **CM** version, manual override boot protected
- **CS** version, with metal ring nut provided with a M4 screw and a blocking locknut to allow the continuous mechanical operations.



CAUTION! The manual override use doesn't allow any proportional regulation; indeed using this kind of override, the main stage spool will open completely and the whole inlet pressure will pass through A or B line.

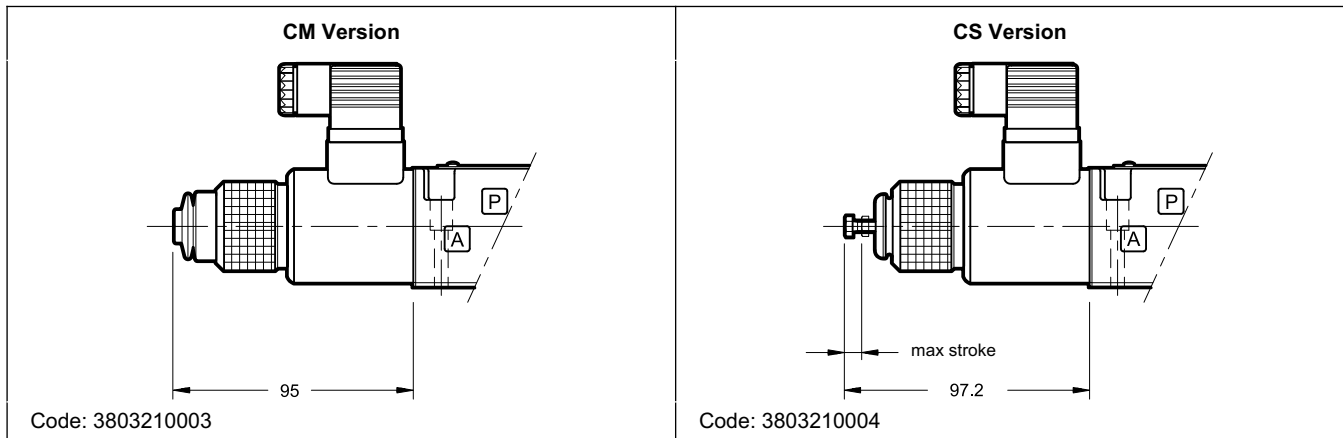

12 - HYDRAULIC FLUIDS

Use mineral oil-based hydraulic fluids HL or HM type, according to ISO 6743-4. For these fluids, use NBR seals. For fluids HFDR type (phosphate esters) use FPM seals (code V). For the use of other kinds of fluid such as HFA, HFB, HFC, please consult our technical department.

Using fluids at temperatures higher than 80 °C causes a faster degradation of the fluid and of the seals characteristics.

The fluid must be preserved in its physical and chemical characteristics.

13 - INSTALLATION

ZDE3G* valves can be installed in any position without impairing correct operation. Ensure that there is no air in the hydraulic circuit. Connect the valve T port directly to the tank. Add any backpressure value detected in the T line to the reduced pressure value.

Maximum admissible backpressure in the T line, under operational conditions, is 30 bar.

Valves are fixed by means of screws or tie rods on a flat surface with planarity and roughness equal to or better than those indicated in the relative symbols. If minimum values are not observed, fluid can easily leak between the valve and support surface.

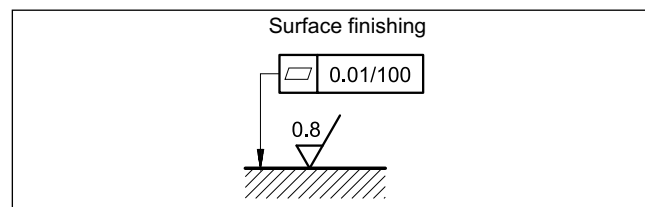



14 - ACCESSORIES

(to be ordered separately)

14.1 - Mating connectors

Mating connectors must be ordered separately. See catalogue 89 000.



For K11 and K16 versions we recommend the choice of a metal connector to avoid electromagnetic disturbances and to comply with EMC regulations on electromagnetic compatibility. If you opt for a plastic connector, make sure that it guarantees and maintains the IP and EMC protection characteristics of the valve.

14.2 - Mating connectors for fieldbus communication and for sensors.

Duplomatic offers spare parts to be wired and also ready-to-use cord sets. Please refer to cat. 89 000.

14.3 - Connection cable

The optimal wiring provides for 7 isolated conductors, with separate screen for the signal wires (command, monitor) and an overall screen.

Cross section for power supply:

- up to 20 m cable length : 1,0 mm²
- up to 40 m cable length : 1,5 mm² (IO-Link excluded)

Cross section for signals (command, monitor):

- 0,50 mm²

14.4 - Kit for start-up LINPC-USB

Device for service start-up and diagnostic, see catalogue 89 850.

15 - SUBPLATES

(see catalogue 51 000)

PMMD-AI3G rear ports
PMMD-AL3G side ports
Ports dimensions: P, T, A, B: 3/8" BSP



ZDE3G*

SERIES 32



DIPLOMATIC MS S.p.A.

via M. Re Depaulini 24 • 20015 PARABIAGO (MI) • ITALY
tel. +39 0331.895.111 • www.diplomatic.com • e-mail: sales.exp@diplomatic.com