

DZCE*

PRESSURE REDUCING VALVE WITH PROPORTIONAL CONTROL

SERIES 11

DZCE5 **CETOP P05**
DZCE5R **ISO 4401-05**
DZCE7 **ISO 4401-07**
DZCE8 **ISO 4401-08**

p max **350** bar
Q max (see table of performances)

OPERATING PRINCIPLE

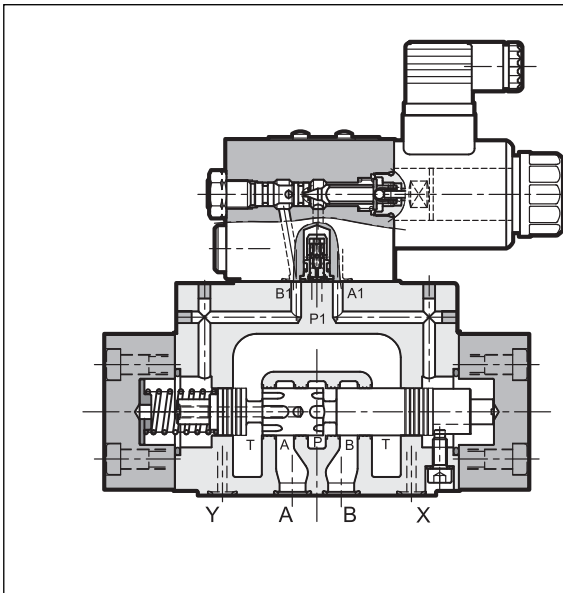

- The DZCE* are pressure reducing valves with electric proportional control and mounting interface in compliance with ISO 4401 standards.
- These valves, besides reducing the pressure from line P to working line A, allow the flow to return from the line A to the return line T when a pressure greater than the set value is generated in the downstream circuit (flow path A): a typical case of hydraulic counterweight or load balancing.
- The pressure can be modulated continuously in proportion to the current supplied to the solenoid.
- They can be controlled directly by a current control supply unit or by means of the electronic control units (par. 12) to exploit valve performance to the full .
- They are available in CETOP P05, ISO 4401-05, ISO 4401-07 and ISO 4401-08 sizes.
- Every size can be supplied with several controlled flow rates, up to 500 l/min.

PERFORMANCES

(obtained with mineral oil with viscosity of 36 cSt at 50°C and electronic control card)

		DZCE5 DZCE5R	DZCE7	DZCE8
Maximum operating pressure	bar	350		
Maximum flow	l/min	150	300	500
Step response		see paragraph 6		
Hysteresis (with PWM 200 Hz)	% of p _{max}	< 4%		
Repeatability	% of p _{max}	< ±2%		
Electrical characteristic		see paragraph 5		
Ambient temperature range	°C	-20 / +60		
Fluid temperature range	°C	-20 / +80		
Fluid viscosity range	cSt	10 ÷ 400		
Fluid contamination degree	According to ISO 4406:1999 class 18/16/13			
Recommended viscosity	cSt	25		
Mass	kg	7	9,2	15,3

HYDRAULIC SYMBOL

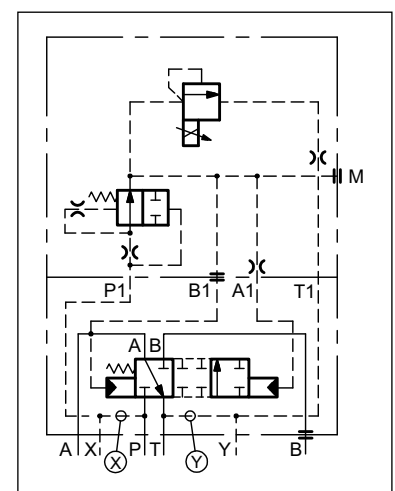

1 - IDENTIFICATION CODE

D	Z	C	E	-	/	11	-	/	K1
----------	----------	----------	----------	----------	----------	-----------	----------	----------	-----------

Pressure reducing valve

Electric proportional control

Nominal size:
5 = CETOP P05 (NOTE)
5R = ISO 4401-05
7 = ISO 4401-07
8 = ISO 4401-08

Pressure control range
070 = 1 ÷ 70 bar
140 = 1 ÷ 140 bar
210 = 1 ÷ 210 bar
300 = 1 ÷ 300 bar

Series N. (the overall and mounting dimensions remain unchanged from 10 to 19)

Coil electrical connection: for connector type EN 175301-803 (standard)

Supply voltage:
D12 = voltage 12V DC
D24 = voltage 24V DC

Drainage: **I** = internal
E = external

Piloting: **I** = internal
E = external

Seals:
N = NBR seals for mineral oil (standard)
V = FPM seals for special fluids

NOTE: This version is interchangeable with the model ZCE4 Diplomatic.

2 - CHARACTERISTIC CURVES

(obtained with mineral oil with viscosity of 36 cSt at 50°C and electronic control card)

2.1 - Characteristic curves DZCE5 and DZCE5R

ADJUSTMENT

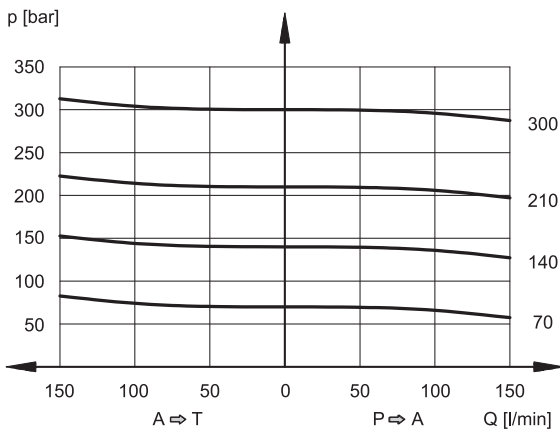

MIN. CONTROLLED PRESSURE $p_{min} = f(Q)$

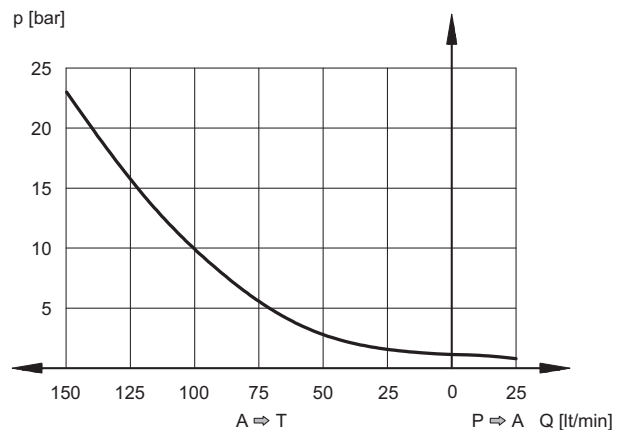

2.2 - Characteristic curves DZCE7

ADJUSTMENT

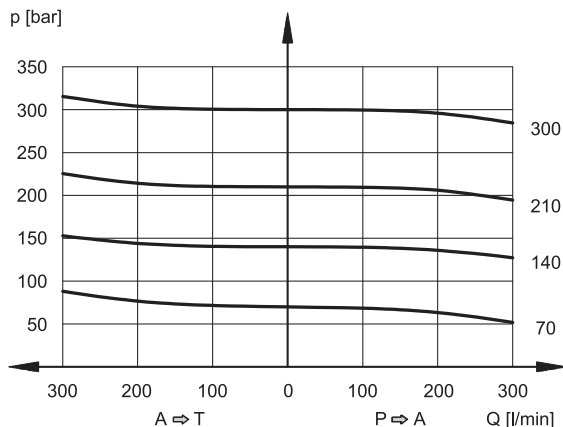

MIN. CONTROLLED PRESSURE $p_{min} = f(Q)$

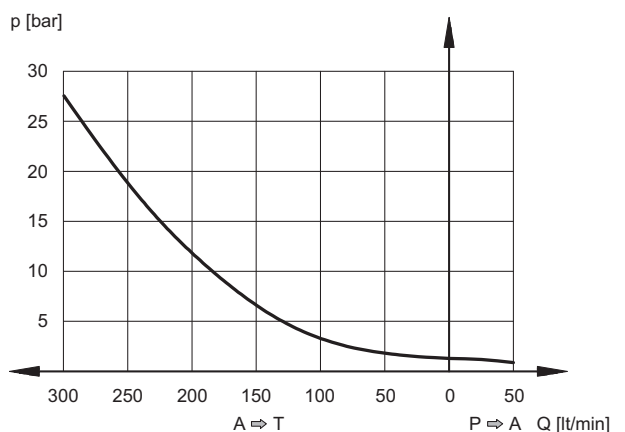

2.3 - Characteristic curves DZCE8

ADJUSTMENT

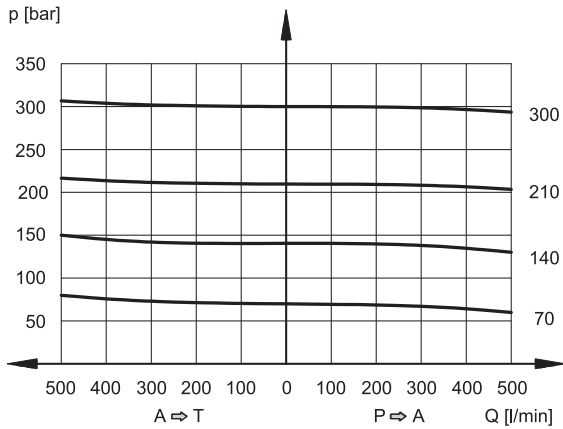

MIN. CONTROLLED PRESSURE $p_{min} = f(Q)$

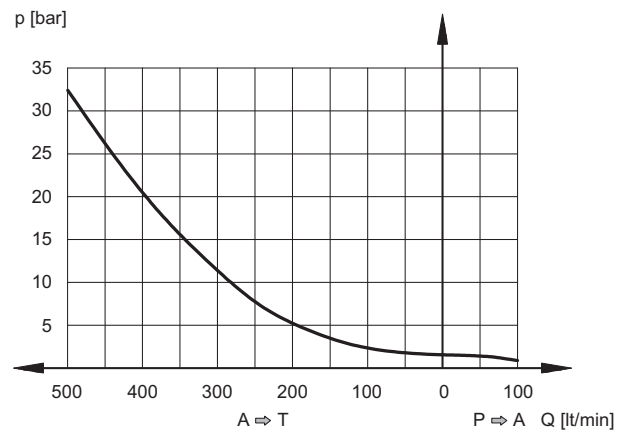

2.4 - Pressure control $p = f(I)$ DZCE5, DZCE5R, DZCE7 and DZCE8

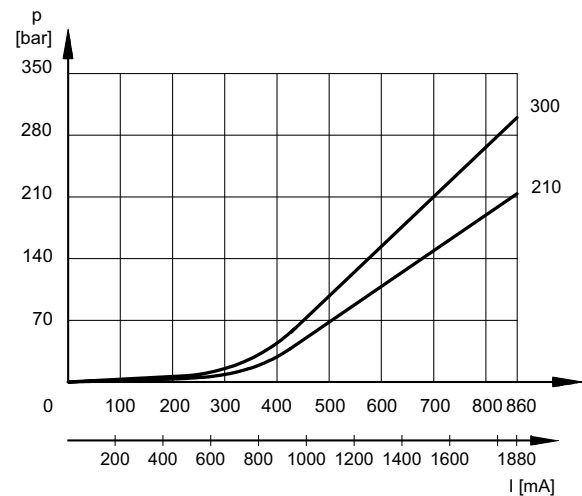
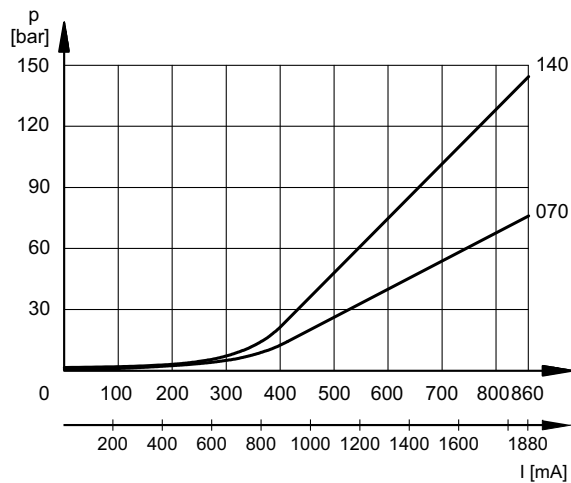

3 - HYDRAULIC FLUIDS

Use mineral oil-based hydraulic fluids HL or HM type, according to ISO 6743-4. For these fluids, use NBR seals (code N). For fluids HFDR type (phosphate esters) use FPM seals (code V). For the use of other kinds of fluid such as HFA, HFB, HFC, please consult our technical department. Using fluids at temperatures higher than 80 °C causes a faster degradation of the fluid and of the seals characteristics.

The fluid must be preserved in its physical and chemical characteristics.

4 - PILOTING AND DRAINAGE

DZCE* valves are available with piloting and drainage, both internal and external.

We suggest using the version with external drainage, that allows a higher backpressure on the unloading.

VALVE TYPE		Plug assembly	
		X	Y
IE	INTERNAL PILOT AND EXTERNAL DRAIN	NO	YES
II	INTERNAL PILOT AND INTERNAL DRAIN	NO	NO
EE	EXTERNAL PILOT AND EXTERNAL DRAIN	YES	YES
EI	EXTERNAL PILOT AND INTERNAL DRAIN	YES	NO

PRESSURES (bar)

Pressure	MIN	MAX
Piloting pressure on X port	30	350
Pressure on T port with internal drain	-	2
Pressure on T port with external drain	-	250

DZCE5 and DZCE5R

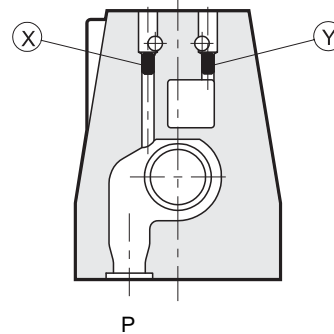

X: M5x6 plug for external pilot
Y: M5x6 plug for external drain

P

DZCE7

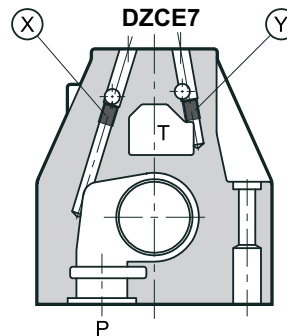

X: M6x8 plug for external pilot
Y: M6x8 plug for external drain

P

DZCE8

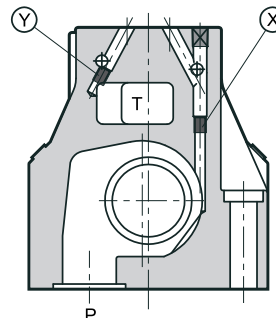

X: M6x8 plug for external pilot
Y: M6x8 plug for external drain

P

5 - ELECTRICAL CHARACTERISTICS

Proportional solenoid

The proportional solenoid comprises two parts: tube and coil.

The tube, screwed to the valve body, contains the armature which is designed to maintain friction to a minimum thereby reducing hysteresis.

The coil is mounted on the tube secured by means of a lock nut.

It can be rotated through 360° depending on installation clearances.

NOMINAL VOLTAGE	V DC	12	24
RESISTANCE (at 20°C)	Ω	3.66	17.6
NOMINAL CURRENT	A	1.88	0.86
DUTY CYCLE	100%		
ELECTROMAGNETIC COMPATIBILITY (EMC)	According to 2014/30/EU		
CLASS OF PROTECTION: atmospheric agents (EN 60529) coil insulation (VDE 0580) Impregnation	IP 65 class H class F		



6 - STEP RESPONSE

(measured with mineral oil with viscosity of 36 cSt at 50°C with electronic control card)

Step response is the time taken for the valve to reach 90% of the set pressure value following a step change of reference signal.

REFERENCE SIGNAL STEP	0 →100%	100→0%
response times [ms]		
DZCE5 and DZCE5R	100	70
DZCE7	100	50
DZCE8	100	50

7 - INSTALLATION

We recommend to install the DZCE* valve either in horizontal position, or vertical position with the solenoid downward. If the valve is installed in vertical position and with the solenoid upward, you must consider possible variations of the minimum controlled pressure, if compared to what is indicated in paragraph 2.

Ensure that there is no air in the hydraulic circuit. In particular applications, it can be necessary to vent the air entrapped in the solenoid tube, using the special drain screw and then ensure to screw it correctly.

Connect the valve T port directly to the tank. Add any backpressure value detected in the T line to the controlled pressure value.

Maximum admissible backpressure in the T line, under operational conditions, is 2 bar.

Valves are fixed by means of screws or tie rods on a flat surface with planarity and roughness equal to or better than those indicated in the relative symbols. If minimum values are not observed, fluid can easily leak between the valve and support surface.

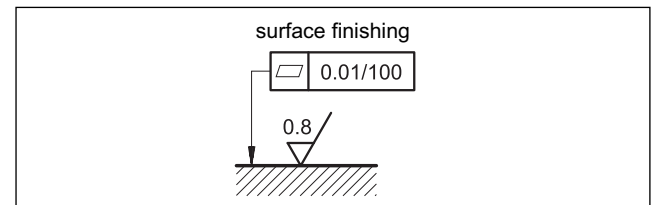

8 - DZCE5 AND DZCE5R OVERALL AND MOUNTING DIMENSIONS

dimensions in mm

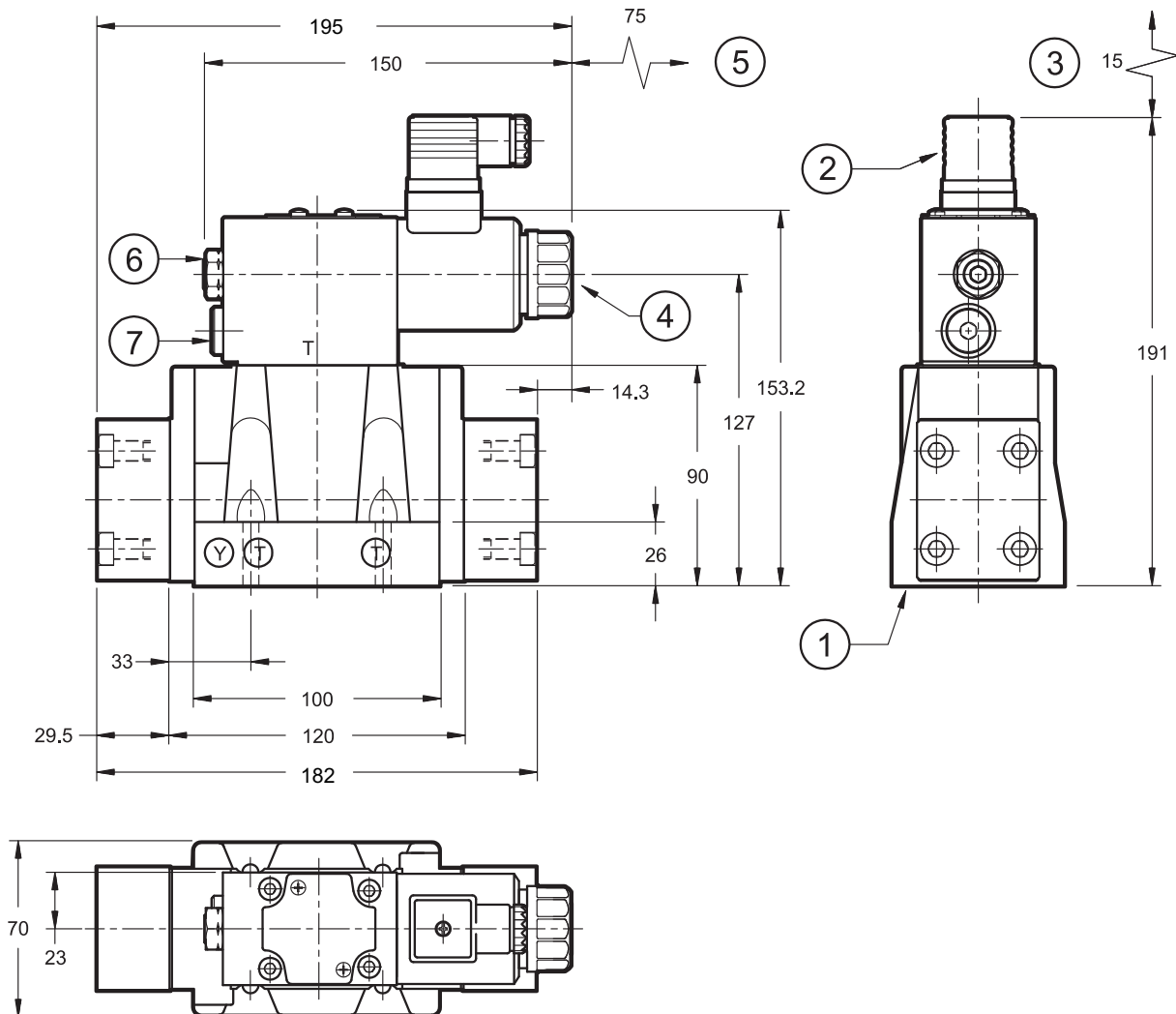

NOTE: at the first start up, or after a long period of no use, it is necessary to vent the air through the breather (4) placed at the end of the solenoid tube.

Valve fastening: N. 4 bolts SHC M6x35 - ISO 4762
Tightening torque: 8 Nm (A 8.8 bolts)
Thread of mounting holes: M6x10
Sealing rings: N. 5 OR type 2050 (12.42x1.78) - 90 Shore N. 2 OR type 2037 (9.25x1.78) - 90 Shore

1	Mounting surface with sealing rings
2	EN 175301-803 electrical connector (included in the supply)
3	Connector removal space
4	Breather (Allen key 4)
5	Coil removal space
6	Adjustment sealing made in factory. Do not unscrew the nut.
7	Pressure gauge port 1/4" BSP

9 - DZCE7 OVERALL AND MOUNTING DIMENSIONS

dimensions in mm

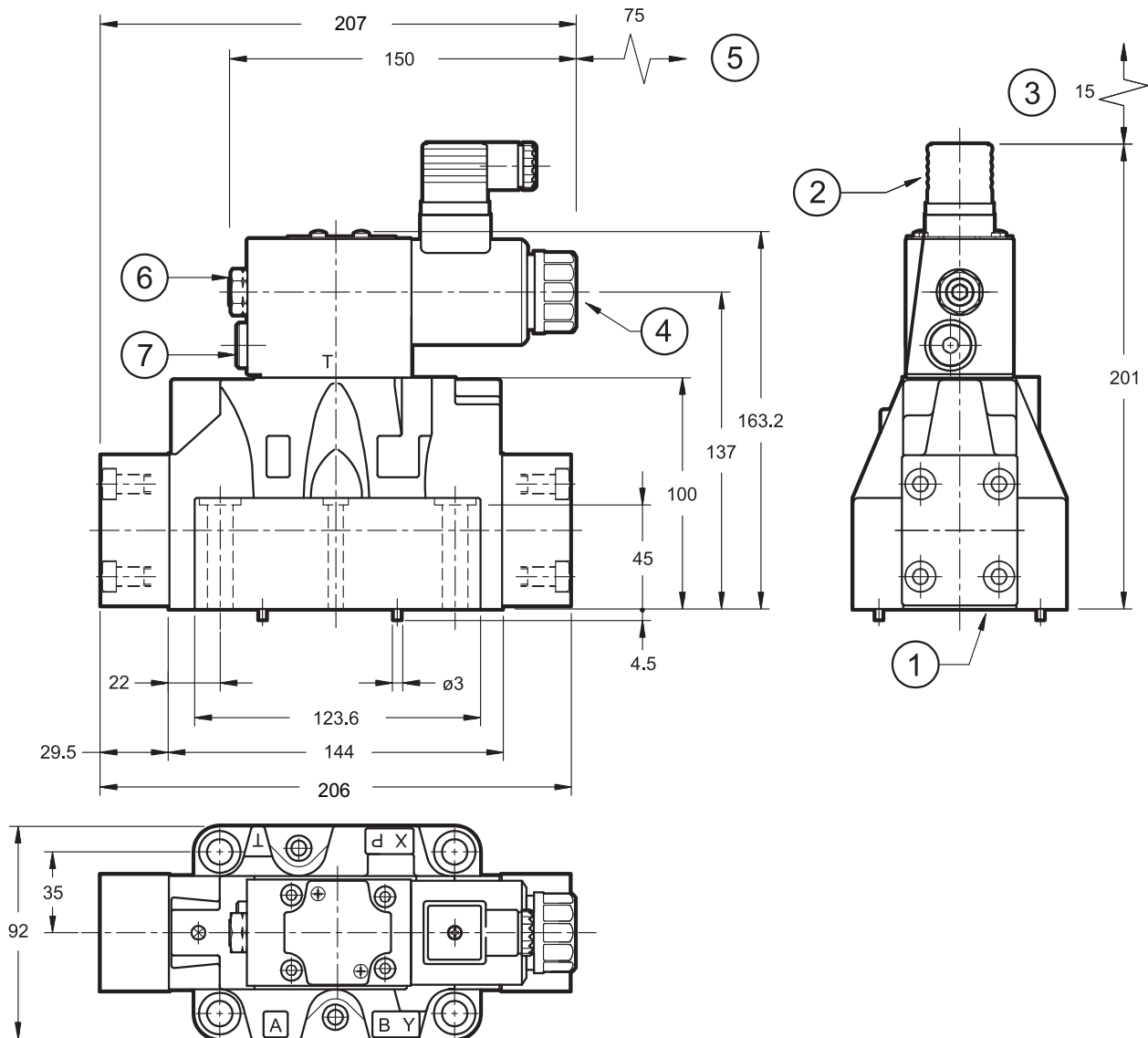

NOTE: at the first start up, or after a long period of no use, it is necessary to vent the air through the breather (4) placed at the end of the solenoid tube.

Single valve fastening:	N. 4 SHC M10x60 bolts - ISO 4762 N. 2 SHC M6x60 bolts - ISO 4762
Tightening torque M10x60:	40 Nm (A 8.8 bolts)
M6x60:	8 Nm (A 8.8 bolts)
Thread of mounting holes:	M6x18; M10x18
Sealing rings:	N. 4 OR type 130 (22.22x2.62) - 90 Shore N. 2 OR type 2043 (10.82x1.78) - 90 Shore

1	Mounting surface with sealing rings
2	EN 175301-803 electrical connector (included in the supply)
3	Connector removal space
4	Breather (Allen key 4)
5	Coil removal space
6	Adjustment sealing made in factory. Do not unscrew the nut.
7	Pressure gauge port 1/4" BSP

11 - MOUNTING SURFACES

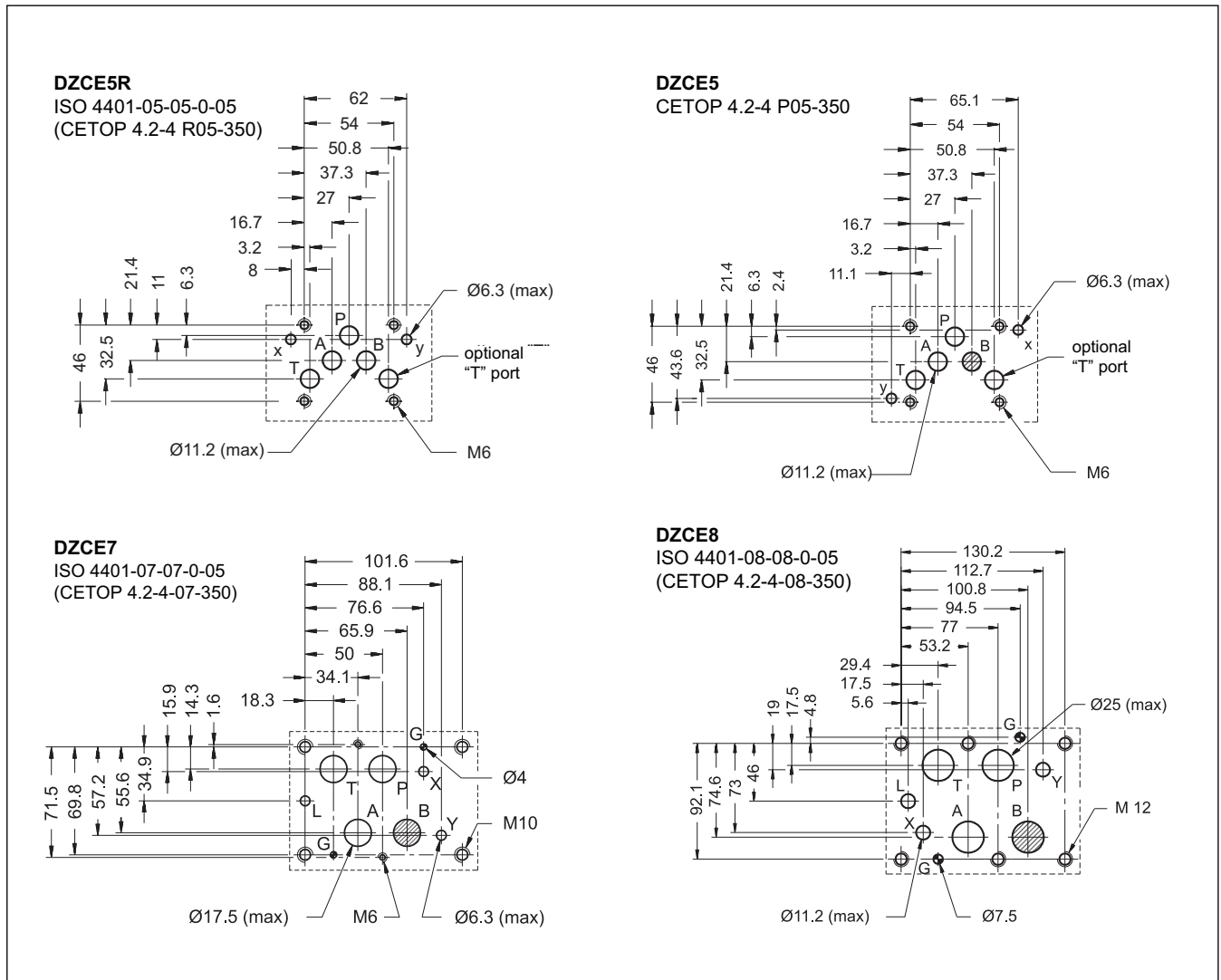

12 - ELECTRONIC CONTROL UNITS

EDC-112	for solenoid 24V DC	plug version	see cat. 89 120
EDC-142	for solenoid 12V DC		
EDM-M112	for solenoid 24V DC	DIN EN 50022 rail mounting	see cat. 89 250
EDM-M142	for solenoid 12V DC		
UEIK-11	for solenoid 24V DC	Eurocard type	see cat. 89 300

13 - SUBPLATES

(see catalogue 51 000)

	DZCE5	DZCE7	DZCE8
Model with rear ports	PME4-AI5G	PME07-AI6G	-
Model with side ports	PME4-AL5G	PME07-AL6G	PME5-AL8G
Thread of ports:	P - T - A - B X - Y	3/4" BSP 1/4" BSP	1" BSP 1/4" BSP



DZCE*
SERIES 11

DUPLOMATIC
MOTION SOLUTIONS

DUPLOMATIC MS S.p.A.

via M. Re Depaolini 24 • 20015 PARABIAGO (MI) • ITALY
tel. +39 0331.895.111 • www.duplomatic.com • e-mail: sales.exp@duplomatic.com