

# DSPE\*J\*

## PROPORTIONAL DIRECTIONAL VALVE PILOT OPERATED WITH FEEDBACK AND INTEGRATED ELECTRONICS

### SUBPLATE MOUNTING

- DSPE5J\* CETOP P05
- DSPE5RJ\* ISO 4401-05
- DSPE7J\* ISO 4401-07
- DSPE8J\* ISO 4401-08
- DSPE10J\* ISO 4401-10
- DSPE11J\* ISO 4401-10 oversize ports

### OPERATING PRINCIPLE

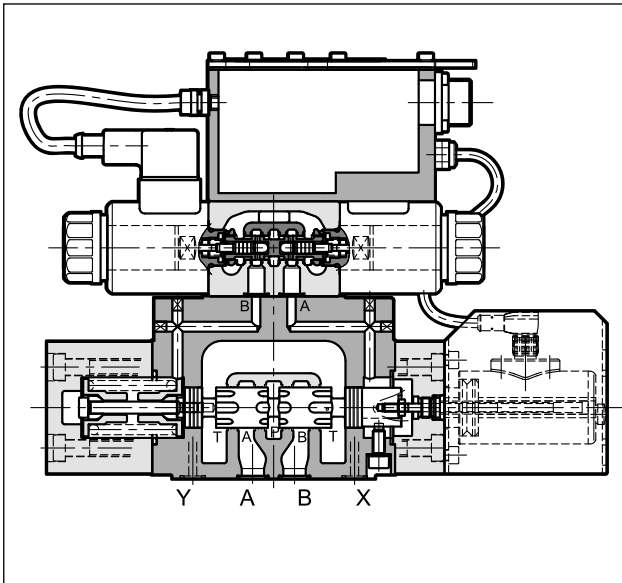

- The DSPE\*J\* are proportional directional valve operated with feedback and integrated electronics and with mounting interface in compliance with ISO 4401 standards.
- They are controlled directly by the integrated electronics. Transducer and digital card allow a fine control of the spool position, reducing both hysteresis and response times and optimizing the valve performance.
- The valves are available with different types of electronics, with analogue or fieldbus interfaces.
- The valves are easy to install. The driver directly manages digital settings.

### HYDRAULIC SYMBOL (typical)

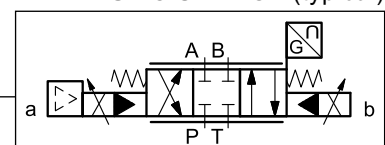

### PERFORMANCES

(obtained with mineral oil with viscosity of 36 cSt at 50°C and p = 140 bar)

		DSPE5J* DSPE5RJ*	DSPE7J*	DSPE8J*	DSPE10J*	DSPE11J*
Max operating pressure: P - A - B ports T port	bar	350 see paragraph 10				
Max flowrate	l/min	180	450	800	1600	2800
Hysteresis	% Q <sub>max</sub>	< 0,5%				
Repeatability	% Q <sub>max</sub>	< ± 0,2%				
Electrical characteristics		see paragraph 4				
Ambient temperature range	°C	-20 / +60				
Fluid temperature range	°C	-20 / +80				
Fluid viscosity range	cSt	10 + 400				
Fluid contamination degree		According to ISO 4406:1999 class 18/16/13				
Recommended viscosity	cSt	25				
Mass	kg	9	11	17.5	56.5	55

## 1 - IDENTIFICATION CODES

### 1.1 - Standard electronics

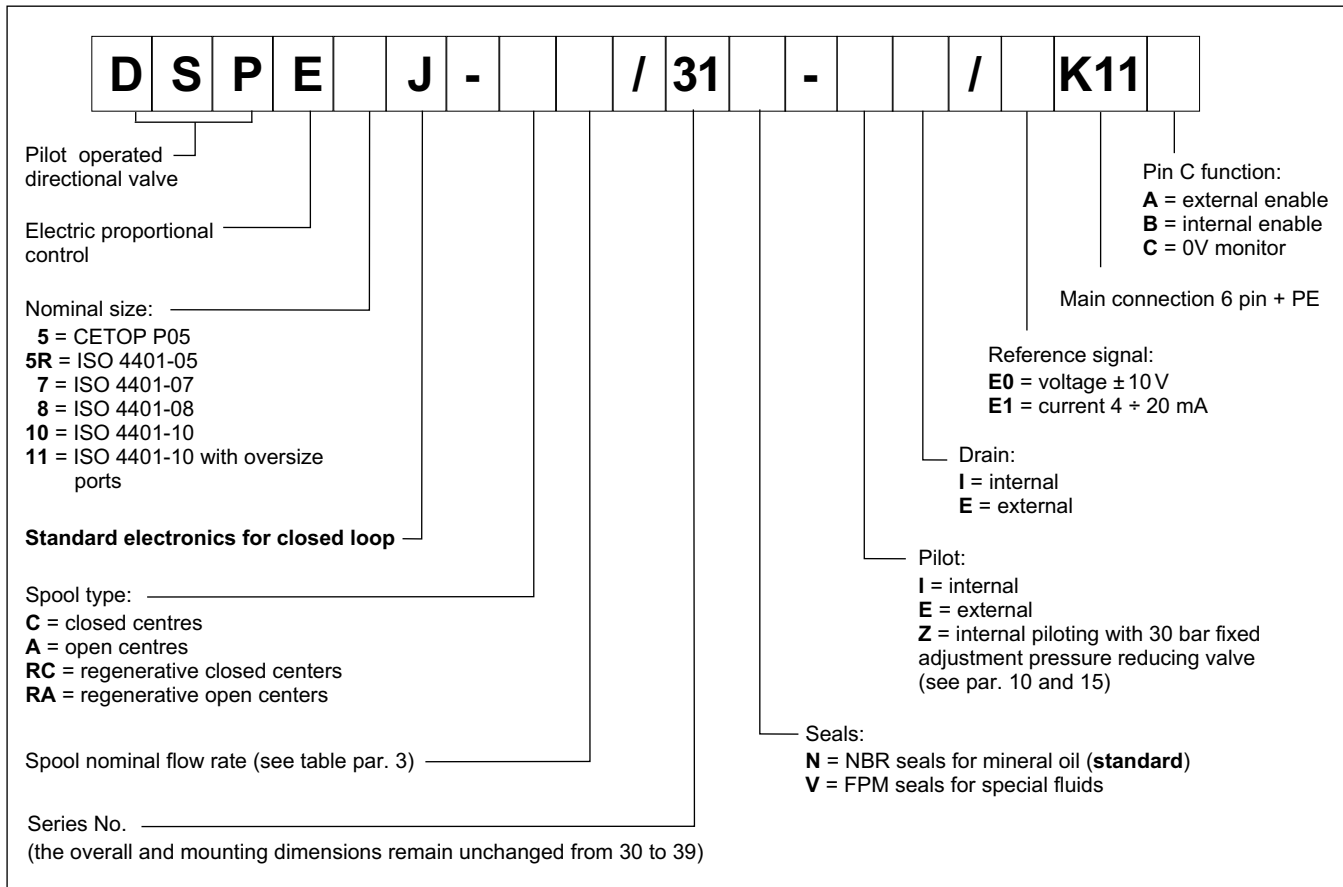

### 1.2 - Compact electronics

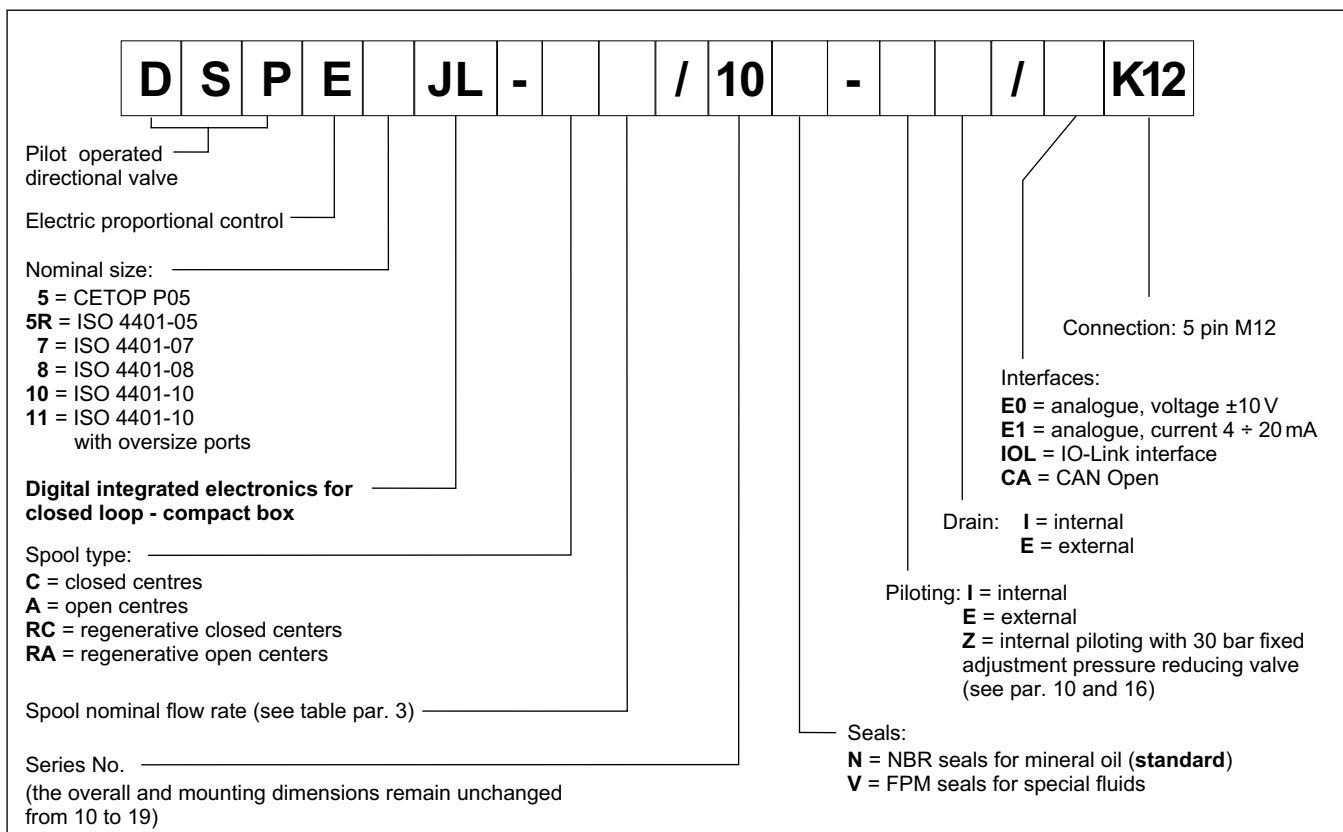

### 1.3 - Electronics with fieldbus communication

<b>D</b>	<b>S</b>	<b>P</b>	<b>E</b>	<b>JH</b>	-	/ 31	-	-	<b>K16</b>	/		
----------	----------	----------	----------	-----------	---	------	---	---	------------	---	--	--

Pilot operated directional valve

Electric proportional control

Nominal size:

- 5 = CETOP P05
- 5R = ISO 4401-05
- 7 = ISO 4401-07
- 8 = ISO 4401-08
- 10 = ISO 4401-10
- 11 = ISO 4401-10 with oversize ports

**Digital integrated electronics for closed loop with fieldbus communication**

Spool type:

- C = closed centres
- A = open centres
- RC = regenerative closed centers
- RA = regenerative open centers

Spool nominal flow rate (see table par. 3)

Series No. (the overall and mounting dimensions remain unchanged from 30 to 39)

Seals:

- N = NBR seals for mineral oil (standard)
- V = FPM seals for special fluids

Piloting:

- I = internal
- E = external
- Z = internal piloting with 30 bar fixed adjustment pressure reducing valve (see par. 10 and 16)

X4 Analogue transducer:

- 0 = none
- 1 = version 1 (single /double transducer)

X7 Digital transducer:

- 0 = none
- 1 = version 1 (SSI type)
- 2 = version 2 (Encoder type)

X2, X3 Field BUS type:

- CA = CAN Open
- PD = PROFIBUS DP
- EC = EtherCAT
- EN = Ethernet /IP
- PN = Profinet
- PL = PowerLink

X1 Main connector configuration:

- D1 = one command
- D0 = full digital version (on request - available for reference signal FD type only)

Connection 11 pin + PE

Reference signal:

- E0 = voltage ±10V
- E1 = current 4 + 20 mA
- FD = full digital version (on request)

Drain:

- I = internal
- E = external

### 2 - COMPARISON AMONG INTEGRATED ELECTRONICS

**J type**

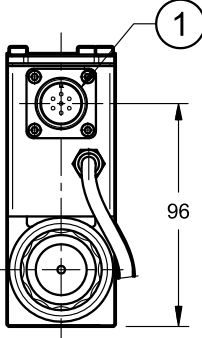

1

96

**JL type**

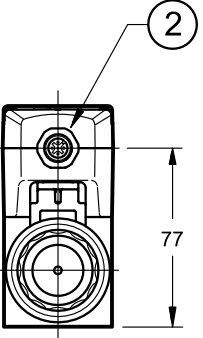

2

77

**JH type**

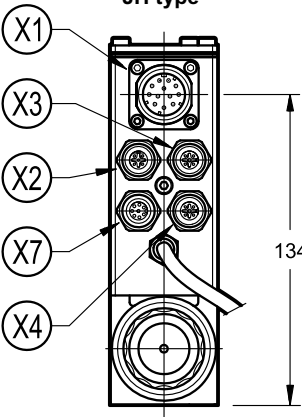

X1

X3

X2

X7

X4

134

dimensions in mm

1	Connection 6 pin + PE
2	Connection M12 5 pin, code A, male
X1	Main connection 11 pin + PE
X2	Fieldbus communication (IN)
X3	Fieldbus communication (OUT)
X4	Connection for analogue transducer
X7	Connection for digital transducer

**NOTE 1:** Depending on the chosen version, X4 and X7 connections may not be present. Please refer to sections 5, 6 and 7 for connections descriptions and pinouts.

**NOTE 2:** Related mating connectors have to be ordered separately. See catalogue 89 000.

### 3 - AVAILABLE CONFIGURATIONS

The valve configuration depends on the combination of spool type and rated flow.

#### 3 positions with spring centring

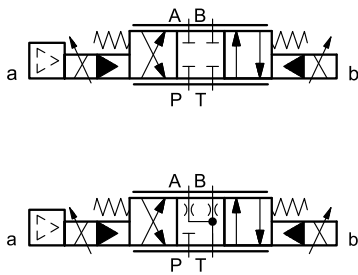

C \*

A \*

valve type	*	Nominal flow with $\Delta p$ 10 bar P-T
DSPE5J*	<b>80</b>	80 l/min
DSPE5RJ*	<b>80/40</b>	80 (P-A) / 40 (B-T) l/min
DSPE7J*	<b>100</b>	100 l/min
	<b>150</b>	150 l/min
DSPE8J*	<b>150/75</b>	150 (P-A) / 75 (B-T) l/min
	<b>200</b>	200 l/min
DSPE8J*	<b>300</b>	300 l/min
	<b>300/150</b>	300 (P-A) / 150 (B-T) l/min
DSPE10J*	<b>350</b>	350 l/min
	<b>500</b>	500 l/min
DSPE10J*	<b>500/250</b>	500 (P-A) / 250 (B-T) l/min
	<b>800</b>	800 l/min
DSPE11J*	<b>800/500</b>	800 (P-A) / 500 (B-T) l/min

#### regenerative spool

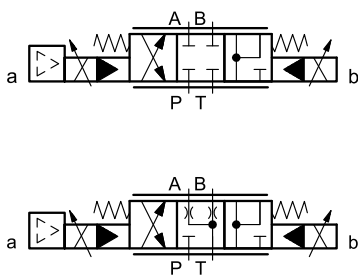

RC \*

RA \*

valve type	*	Nominal flow with $\Delta p$ 10 bar P-T
DSPE7J*	<b>150/75</b>	150 (P-A) / 75 (B-T) l/min
DSPE8J*	<b>300/150</b>	300 (P-A) / 150 (B-T) l/min
DSPE10J*	<b>500/250</b>	500 (P-A) / 250 (B-T) l/min

## 4 - ELECTRONICS COMMON DATA

Duty cycle		100% (continuous operation)
Protection class according to EN 60529		IP65 / IP67
Supply voltage	V DC	24 (from 19 to 30 VDC), ripple max 3 Vpp
Power consumption	VA	25
Maximum solenoid current	A	1.88
Fuse protection, external	A	3
Managed breakdowns		Overload and electronics overheating, cable breakdown, supply voltage failures
Electromagnetic compatibility (EMC) emissions EN 61000-6-4, immunity EN 61000-6-2		According to 2014/30/EU standards

## 5 - DSPE\*J\* - STANDARD ELECTRONICS

### 5.1 - Electrical characteristics

Command signal:	voltage (E0) current (E1)	V DC mA	$\pm 10$ (Impedance $R_i = 11\text{ k}\Omega$ ) $4 \div 20$ (Impedance $R_i = 58\text{ }\Omega$ )
Monitor signal (main spool position):	voltage (E0) current (E1)	V DC mA	$\pm 10$ (Impedance $R_o > 1\text{ k}\Omega$ ) $4 \div 20$ (Impedance $R_o = 500\text{ }\Omega$ )
Communication for diagnostic			LIN-bus Interface (by means of the optional kit)
Connection			6 pin + PE (MIL-C-5015-G - DIN EN 175201-804)

### 5.2 - On-board electronics diagrams

#### VERSION A - External Enable

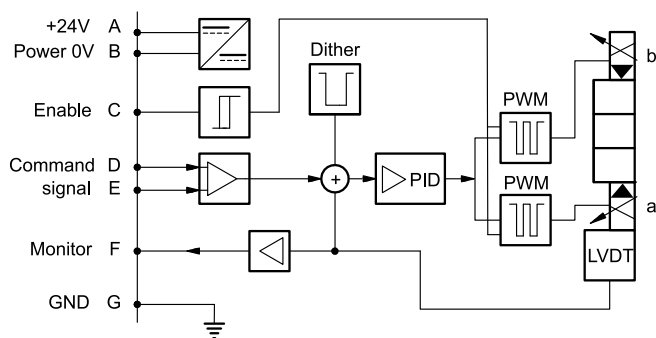

#### VERSION B - Internal Enable

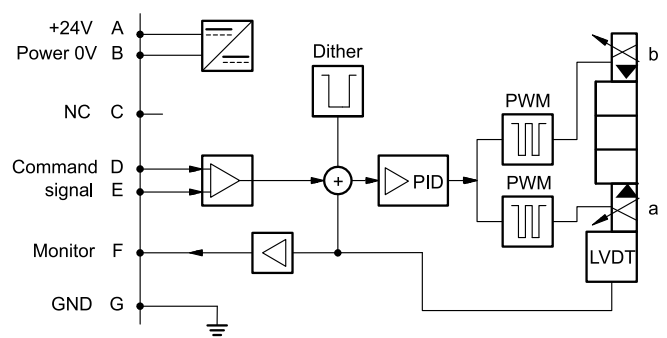

#### VERSION C - 0V Monitor

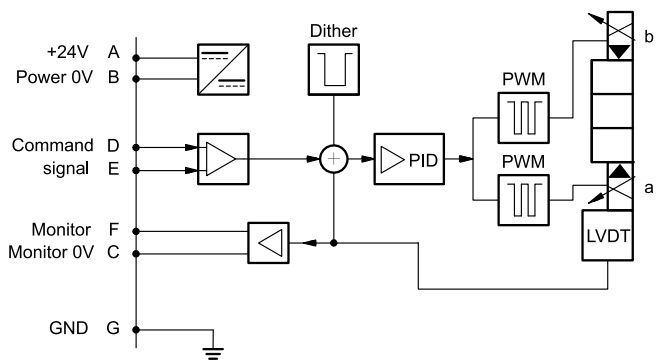

### 5.3 - Versions with voltage command (E0)

The reference signal is between -10V and +10V.. The monitor feature of versions B and C becomes available with a delay of 0,5 sec from the power-on of the card.

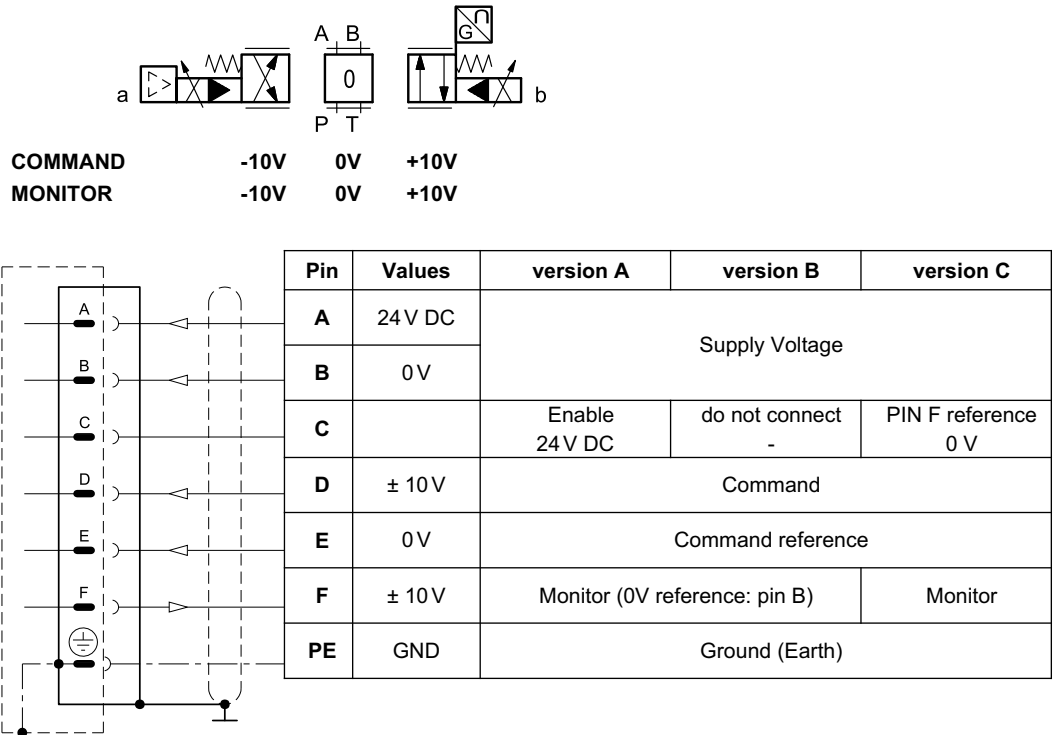

### 5.4 - Versions with current command (E1)

The reference signal is supplied in current  $4 \div 20$  mA. If the current for command is lower the card shows a breakdown cable error. To reset the error is sufficient to restore the signal.

The monitor feature of versions B and C becomes available with a delay of 0,5 sec from the power-on of the card.

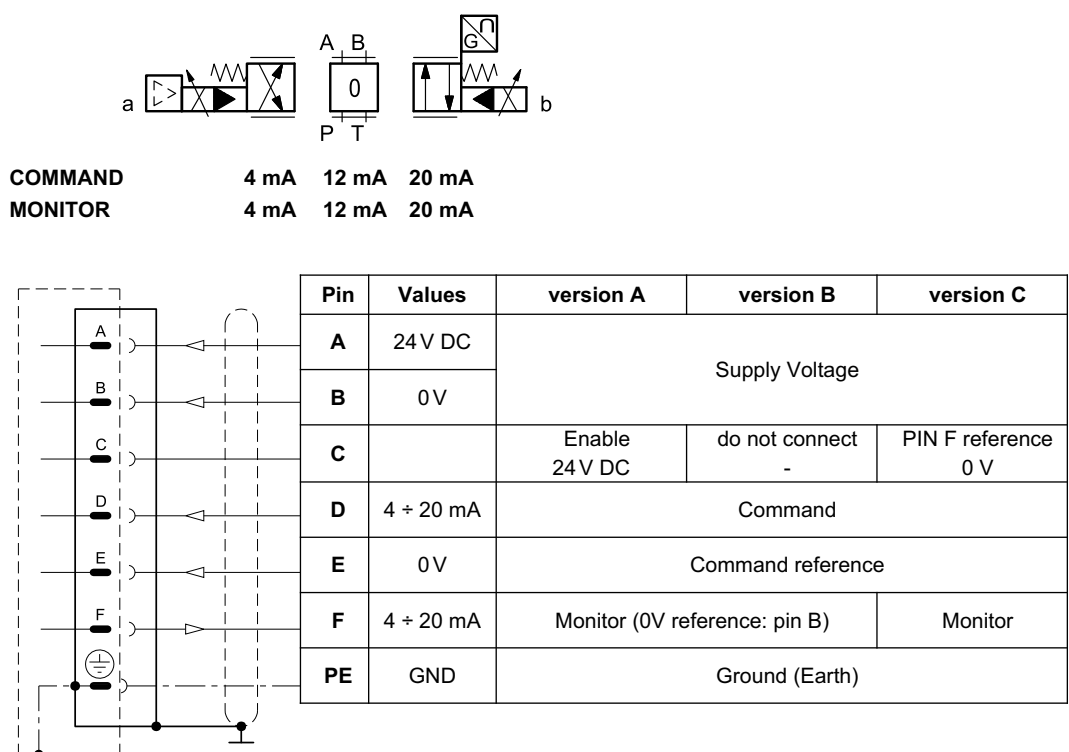

## 6 - DSPE\*JL - COMPACT ELECTRONICS

In versions 'IOL' and 'CA' pin 3 and pin 5 are galvanic isolated up to 100 V to avoid earth loops. In IO-Link networks, the length of the connecting cables is limited to 20 metres.

### 6.1 - Electrical characteristics

Command signal: voltage (E0) current (E1)	V DC mA	$\pm 10$ (Impedance $R_i = 11 \text{ k}\Omega$ ) $4 \div 20$ (Impedance $R_i = 58 \text{ }\Omega$ )
Monitor signal (current to solenoid): voltage (E0) current (E1)	V DC mA	$0 \div 5$ (Impedance $R_o > 1 \text{ k}\Omega$ ) $4 \div 20$ (Impedance $R_o = 500 \text{ }\Omega$ )
IO-Link communication (IOL): Data rate	kBaud	IO-Link Port Class B 230,4
Can Open communication (CA): Data rate	kbit	$10 \div 1000$
Connection		5-pin M12 code A (IEC 61076-2-101)

### 6.2 - Pin tables

#### 'E0' connection

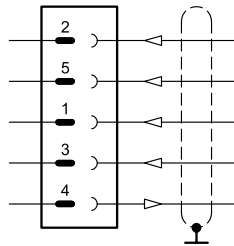

Pin	Values	Function
2	24 V DC	Supply voltage (solenoid and logic)
5	0 V	
1	$\pm 10 \text{ V}$	Command
3	0 V	Command reference
4	$0 \div 5 \text{ V}$	Monitor (0V reference: pin 5)

#### 'E1' connection

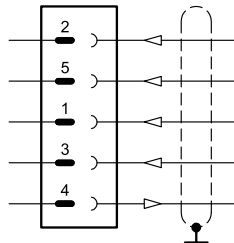

Pin	Values	Function
2	24 V DC	Supply voltage (solenoid and logic)
5	0 V	
1	$4 \div 20 \text{ mA}$	Command
3	0 V	Command reference
4	$4 \div 20 \text{ mA}$	Monitor (0V reference: pin 5)

#### 'IOL' connection

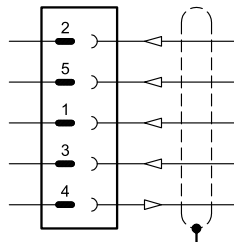

Pin	Values	Function
2	2L+ 24 V DC	Supply of the power stage
5	2L- 0 V (GND)	Internal galvanic isolation from PIN 3
1	1L+ +24 V DC	IO-Link supply voltage
3	1L- 0V (GND)	
4	C/Q	IO-Link Communication

#### 'CA' connection

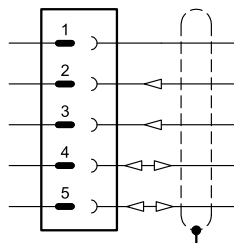

Pin	Values	Function
1	CAN_SH	Shield
2	24 V DC	Supply voltage
3	0V (GND)	
4	CAN H	Bus line (high)
5	CAN_L	Bus line (low)

## 7 - DSPE\*JH - FIELDBUS ELECTRONICS

The 11 + PE pin connection allows separate supply voltage for electronics and solenoids.

Command - valve position schemes as for the standard electronics. Please refer to pictures in par. 5.3 and 5.4.

### 7.1 - Electrical characteristics

Command signal: voltage (E0) current (E1) digital (FD)	V DC mA	$\pm 10$ (Impedance $R_i = 11 \text{ k}\Omega$ ) $4 \div 20$ (Impedance $R_i = 58 \text{ }\Omega$ ) via fieldbus
Monitor signal (main spool position): voltage (E0) current (E1)	V DC mA	$\pm 10$ (Impedance $R_o > 1 \text{ k}\Omega$ ) $4 \div 20$ (Impedance $R_o = 500 \text{ }\Omega$ )
Communication / diagnostic		via Bus register
Communication interface standards CAN Open PROFIBUS DP EtherCAT, Ethernet /IP, Profinet, PowerLink		EN 50325-4 + DS408 EN 50170-2 / IEC 61158 IEC 61158
Communication physical layer CAN Open PROFIBUS DP EtherCAT, Ethernet /IP, Profinet, PowerLink		optical insulated CAN ISO 11898 optical insulated RS485 fast ethernet, insulated 100 Base TX
Power connection		11 pin + PE (DIN 43651)

### 7.2 - X1 Main connection pin table

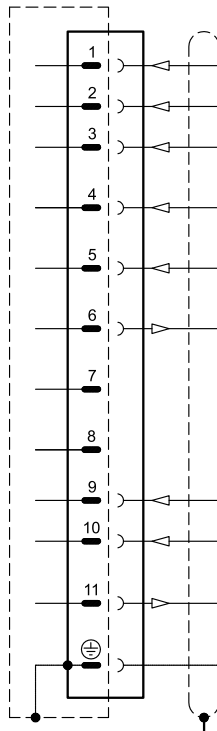
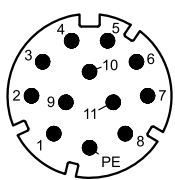

**D1: one command**

Pin	Values	Function
1	24V DC	Main supply voltage
2	0V	
3	24V DC	Enable
4	$\pm 10 \text{ V}$ (E0) $4 \div 20$ (E1)	Command
5	0V	Command reference signal
6	$\pm 10 \text{ V}$ (E0) $4 \div 20$ (E1)	Monitor (0V reference pin 10)
7	NC	do not connect
8	NC	do not connect
9	24V DC	Logic and control supply
10	0V	
11	24V DC	Fault (0V DC) or normal working (24V DC) (0V reference pin 2)
12	GND	Ground (Earth)

**D0: full digital**

Pin	Values	Function
1	24V DC	Main supply voltage
2	0V	
3	24V DC	Enable
4	NC	do not connect
5	NC	do not connect
6	NC	do not connect
7	NC	do not connect
8	NC	do not connect
9	24V DC	Logic and control supply
10	0V	
11	24V DC	Fault (0V DC) or normal working (24V DC) (0V ref. pin 2)
12	GND	Ground (Earth)



### 7.3 - FIELDBUS connections

Please wire following guidelines provided by the relative standards communication protocol.

#### 7.3.1 - Communication connection CA (CAN Open)

**X2 (IN) connection:** M12 A 5 pin female



Pin	Values	Function
1	CAN_SH	Shield
2	NC	Do not connect
3	GND	Signal zero data line
4	CAN_H	Bus line (high)
5	CAN_L	Bus line (low)

**X3 (OUT) connection:** M12 A 5 pin male



Pin	Values	Function
1	CAN_SH	Shield
2	NC	Do not connect
3	GND	Signal zero data line
4	CAN_H	Bus line (high)
5	CAN_L	Bus line (low)

#### 7.3.2 - Communication connection PD (PROFIBUS DP)

**X2 (IN) connection:** M12 B 5 pin male (IN)



Pin	Values	Function
1	+5V	Termination supply signal
2	PB_A	Bus line (high)
3	0V	Data line and termination signal 0
4	PB_B	Bus line (low)
5	SHIELD	

**X3 (OUT) connection:** M12 B 5 pin female



Pin	Values	Function
1	+5V	Termination supply signal
2	PB_A	Bus line (high)
3	0V	Data line and termination signal 0
4	PB_B	Bus line (low)
5	SHIELD	

#### 7.3.3 - Communication connections: EC (EtherCat), EN (Ethernet/IP), PN (PROFINET), PL (POWERLINK)

**X2 (IN) connection:** M12 D 4 pin female



Pin	Values	Function
1	TX+	Transmitter
2	RX+	Receiver
3	TX-	Transmitter
4	RX-	Receiver
HOUSING	shield	

**X3 (OUT) connection:** M12 D 4 pin female



Pin	Values	Function
1	TX+	Transmitter
2	RX+	Receiver
3	TX-	Transmitter
4	RX-	Receiver
HOUSING	shield	

**NOTE:** Shield connection on connector housing is recommended.

## 7.4 - Digital transducer connection

**X7 connection:** M12 A 8 pin female

### VERSION 1: SSI type

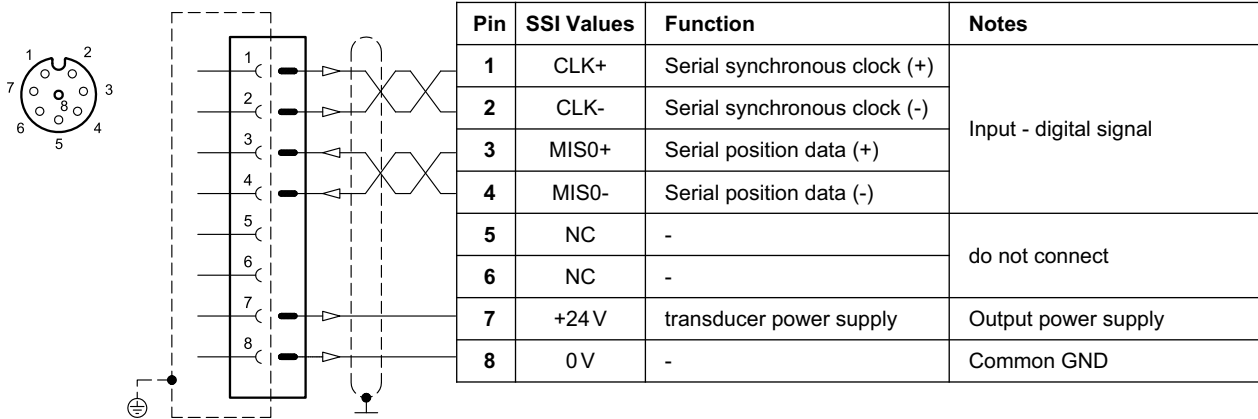

### VERSION 2: ENCODER type

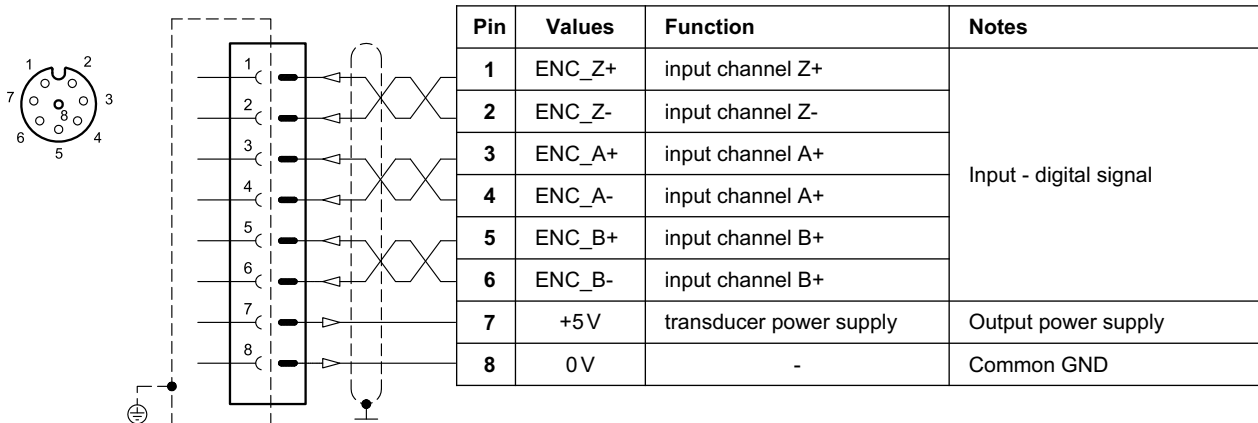

## 7.5 - Analogue transducer connection

**X4 connection:** M12 A 4 pin female

### VERSION 1: single / double transducer

(single or double is a software-selectable option)

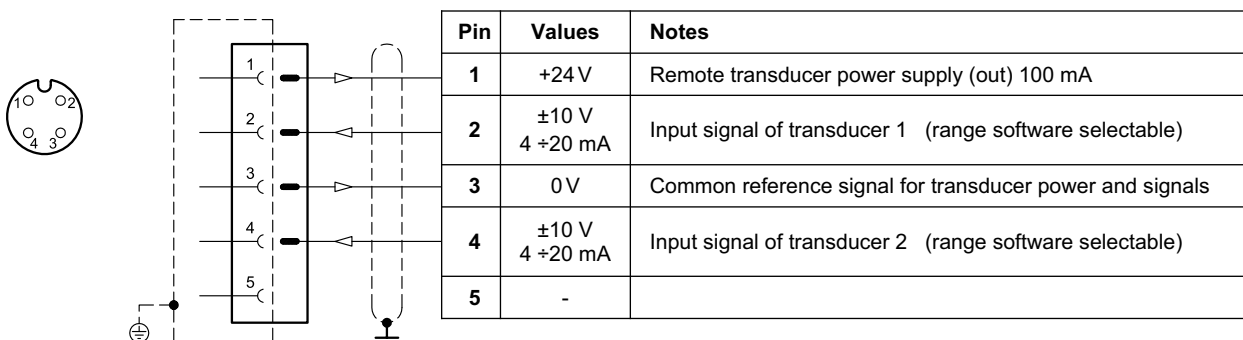



## 8 - CHARACTERISTIC CURVES

(obtained with mineral oil with viscosity of 36 cSt at 50°C and  $p = 140$  bar)

Typical flow rate curves at constant  $\Delta p$  related to the reference signal and measured for the available spools. The  $\Delta p$  values are measured between P and T valve ports.

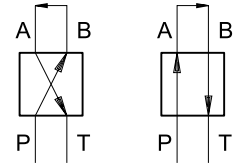

### 8.1 - Characteristic curves DSPE5J\* and DSPE5RJ\*

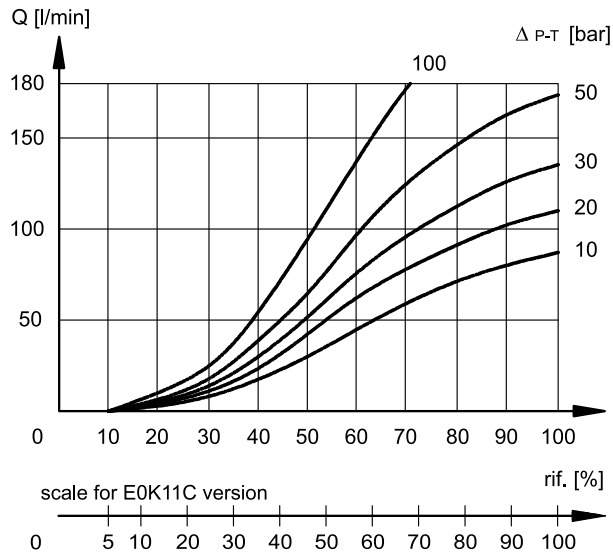

### 8.2 - Characteristic curves DSPE7J\*

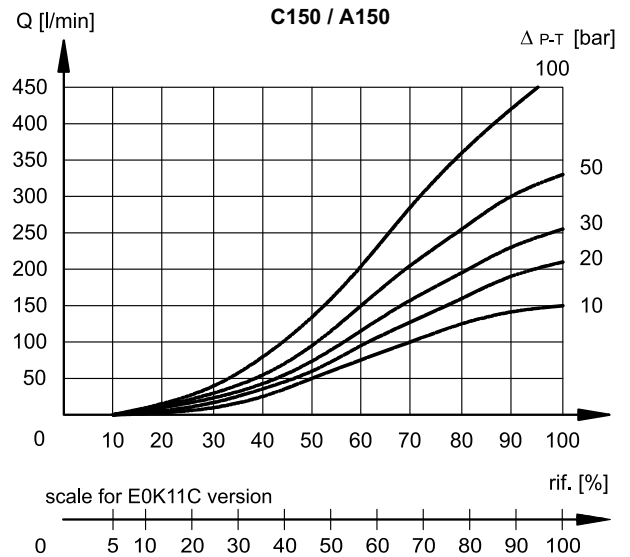
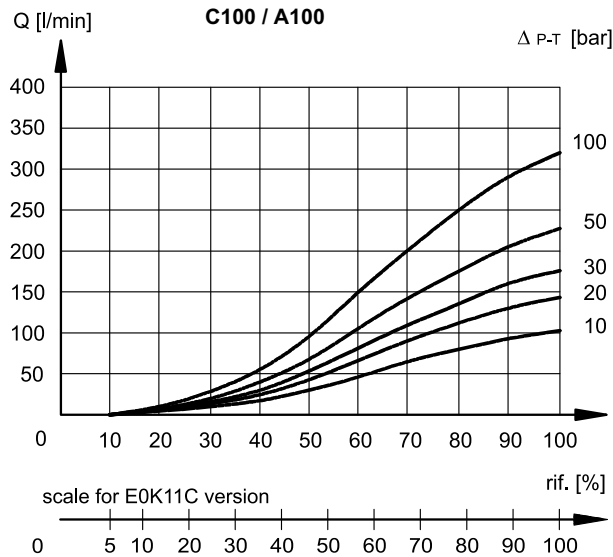



### 8.3 - Characteristic curves DSPE8J\*

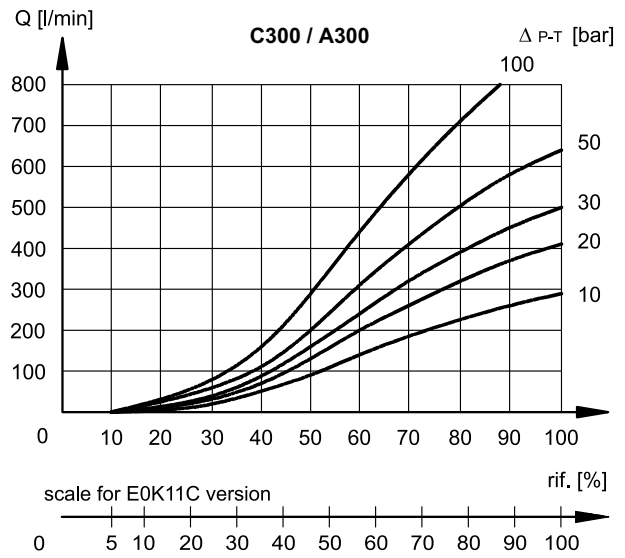
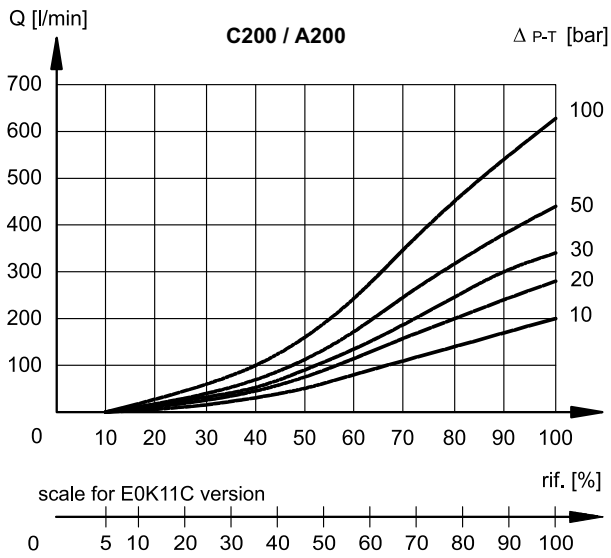

### 8.4 - Characteristic curves DSPE10J\*

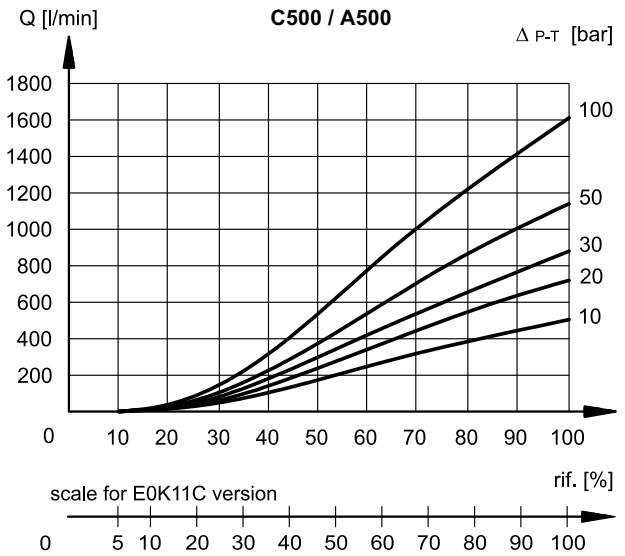
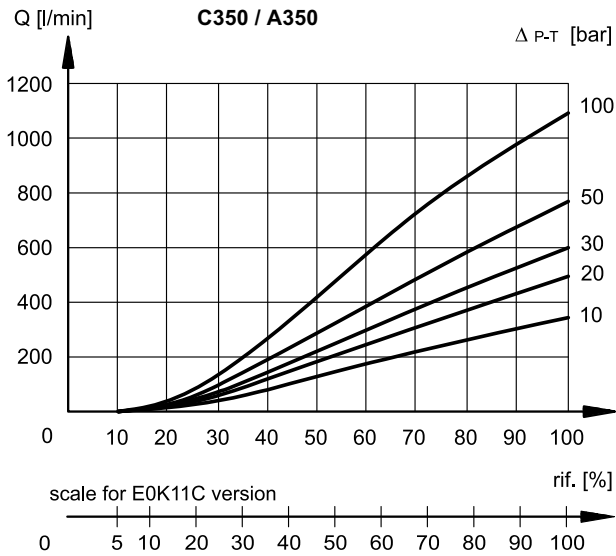

### 8.5 - Characteristic curves DSPE11J\*

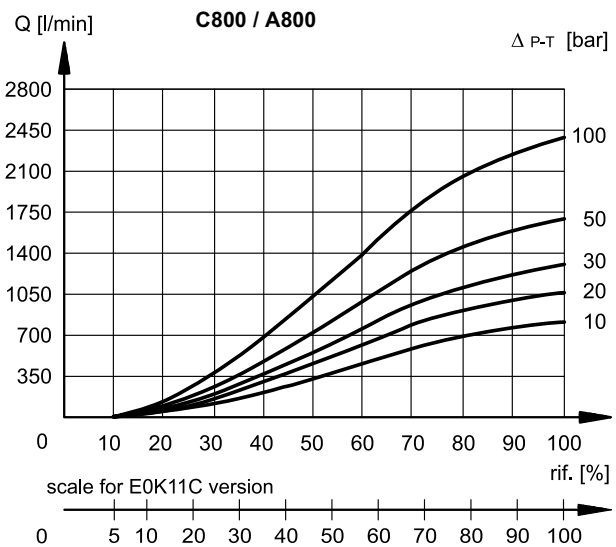

## 9 - STEP RESPONSE

(obtained with mineral oil with viscosity of 36 cSt at 50°C and static pressure 100 bar)

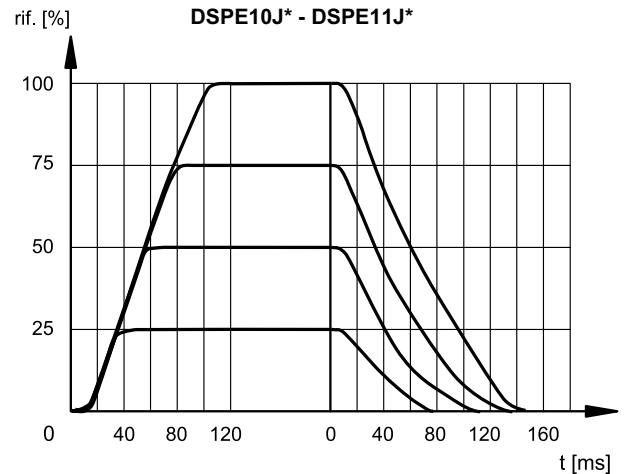
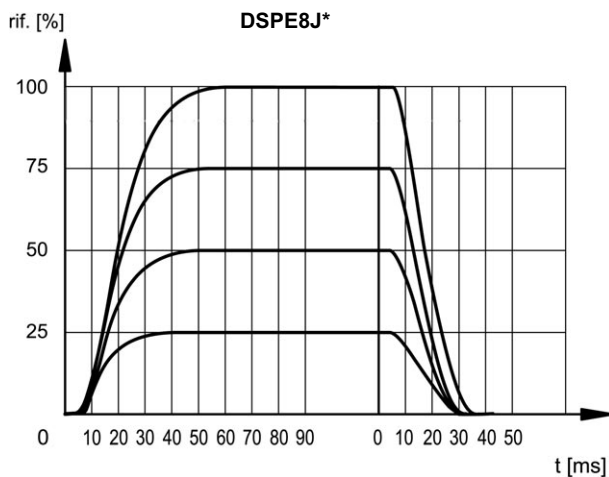
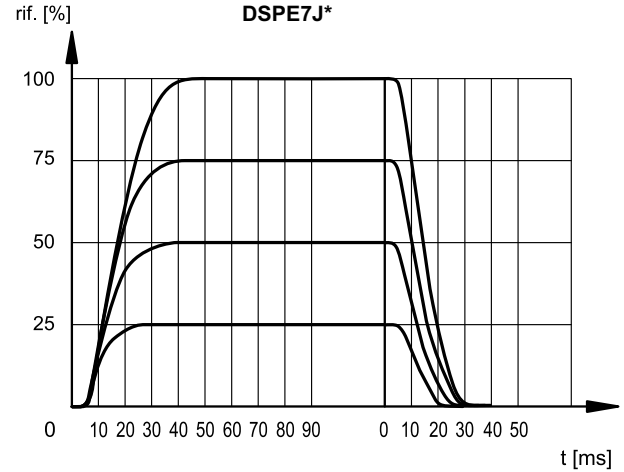
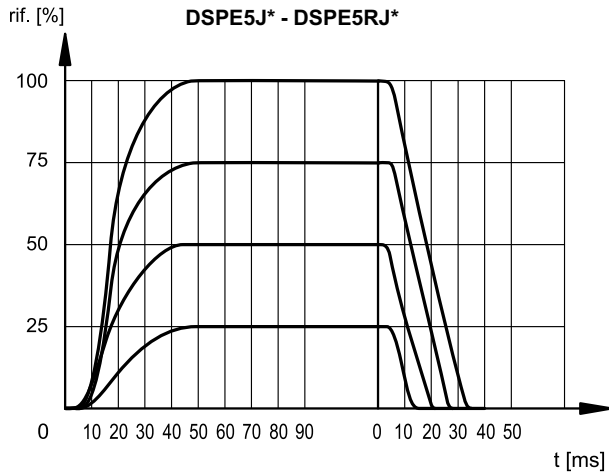

## 10 - HYDRAULIC CHARACTERISTICS

(with mineral oil with viscosity of 36 cSt at 50°C)

FLOWRATES		DSPE5J* DSPE5RJ*	DSPE7J*	DSPE8J*	DSPE10J*	DSPE11J*
Max flow rate	l/min	180	450	800	1600	2800
Piloting flow requested with operation 0 → 100%	l/min	3.5	6.4	15.3	13.7	13.7
Piloting volume requested with operation 0 → 100%	cm <sup>3</sup>	1.7	3.2	9.2	21.6	21.6

PRESSURES (bar)	MIN	MAX
Piloting pressure on X port	30	210 (NOTE)
Pressure on T port with internal drain	–	10
Pressure on T port with external drain	–	250

**NOTE:** if the valve operates with higher pressures it is necessary to use the version with external pilot and reduced pressure.

Otherwise, the valve with internal pilot and pressure reducing valve with 30 bar fixed adjustment can be ordered (piloting type: Z, see section 1).

### 10.1 - Pilot and drain

The DSPE\*J\* valves are available with pilot and drain both internal and external. The version with external drain allows a higher back pressure on the discharge line.

TYPE OF VALVE	Plug assembly	
	X	Y
<b>IE</b> INTERNAL PILOT AND EXTERNAL DRAIN	NO	YES
<b>II</b> INTERNAL PILOT AND INTERNAL DRAIN	NO	NO
<b>EE</b> EXTERNAL PILOT AND EXTERNAL DRAIN	YES	YES
<b>EI</b> EXTERNAL PILOT AND INTERNAL DRAIN	YES	NO

**DSPE5J\* / DSPE5RJ\***

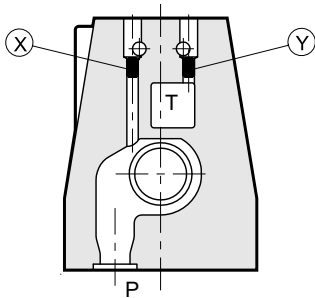

**X:** plug M5x6 for external pilot  
**Y:** plug M5x6 for external drain

**DSPE7J\***

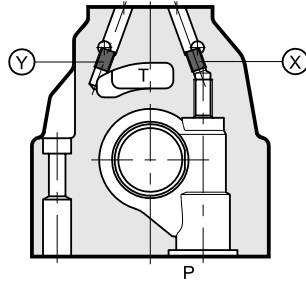

**DSPE8J\***

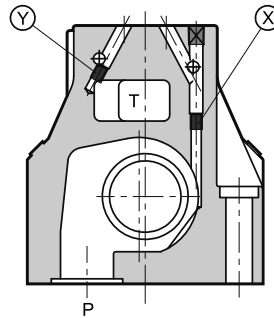

**X:** plug M6x8 for external pilot  
**Y:** plug M6x8 for external drain

**DSPE10J\* / DSPE11J\***

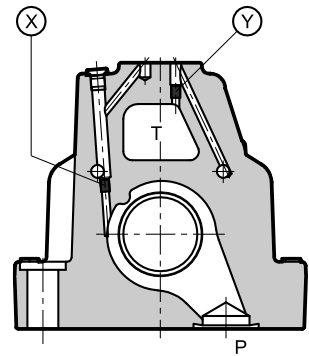

11 - DSPE5J\* AND DSPE5RJ\* - OVERALL AND MOUNTING DIMENSIONS

dimensions in mm

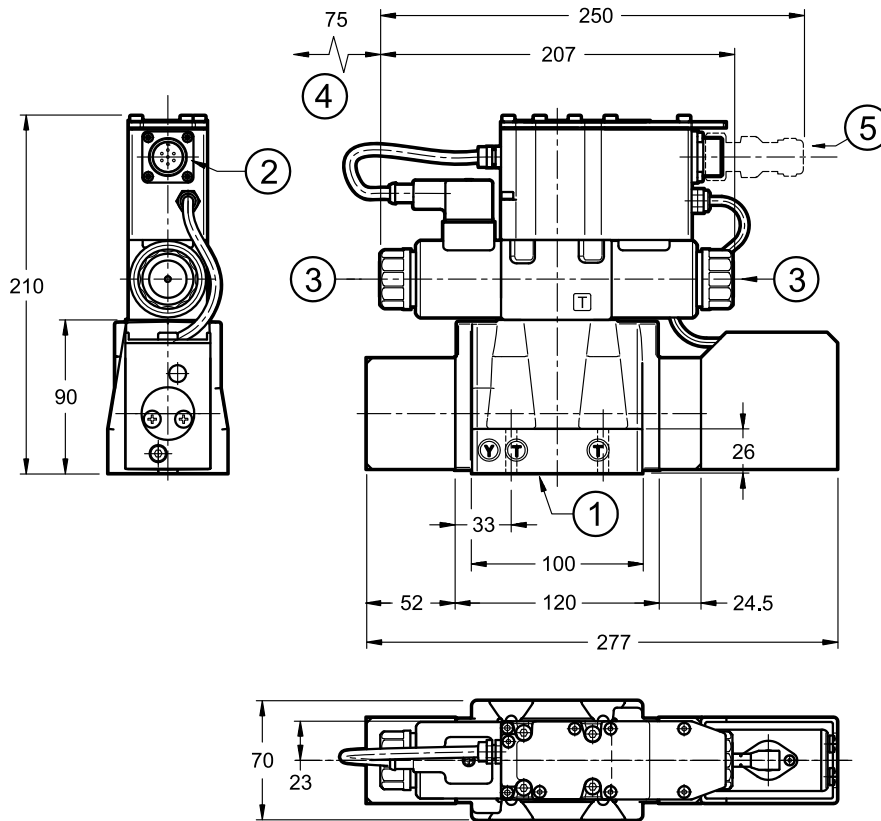

DSPE5JL

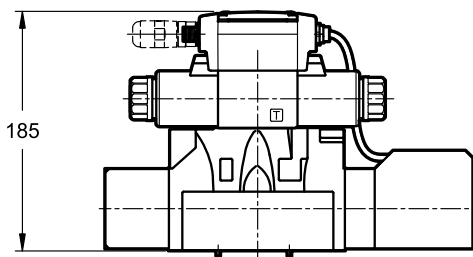

DSPE5JH

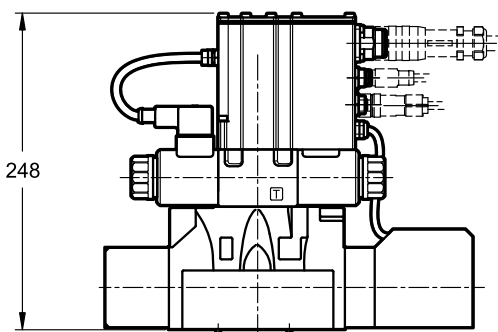

NOTES:

- Overall dimensions with Z option (fixed adjustment pressure reducing valve) at par. 15.
- Mounting surface at par. 16.
- It is recommended to not disassemble the transducer.

1	Mounting surface with sealing rings: 5 OR type 2050 (12.42x1.78) - 90 Shore 2 OR type 2037 (9.25x1.78) - 90 Shore
2	Main connection 6 pin + PE
3	Manual override embedded in the solenoid tube
4	Coil removal space
5	Mating connector. <b>To be ordered separately.</b> See catalogue 89 000

Valve fastening:  
4 SHC screws M6x35 ISO 4762

Tightening torque: 8 Nm (A8.8 screws)

Threads of mounting holes: M6x10

12 - DSPE7J\* - OVERALL AND MOUNTING DIMENSIONS

dimensions in mm

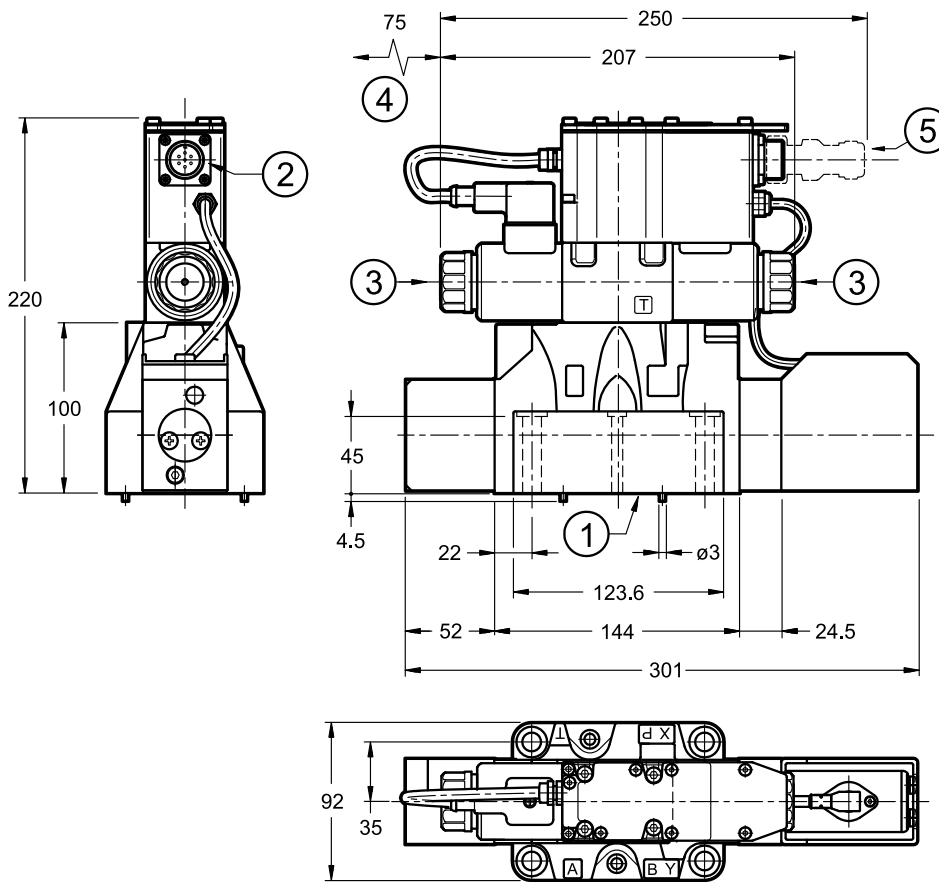

DSPE7JL

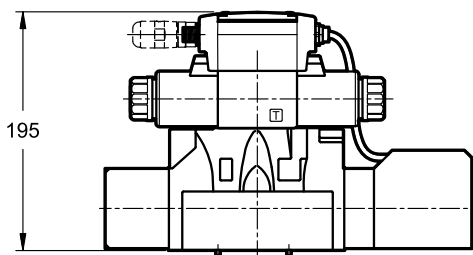

DSPE7JH

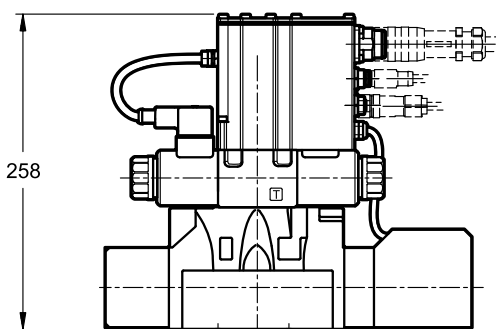

NOTES:

- Overall dimensions with Z option (fixed adjustment pressure reducing valve) at par. 15.
- Mounting surface at par. 16.
- It is recommended to not disassemble the transducer.

1	Mounting surface with sealing rings: 4 OR type 130 (22.22x2.62) - 90 Shore 2 OR type 2043 (10.82x1.78) - 90 Shore
2	Main connection 6 pin + PE
3	Manual override embedded in the solenoid tube
4	Coil removal space
5	Mating connector. <b>To be ordered separately.</b> See catalogue 89 000

Valve fastening: 4 SHC screws M10x60 ISO 4762  
2 SHC screws M6x60 ISO 4762

Tightening torque: M10x60: 40 Nm (A8.8 screws)  
M6x60: 8 Nm (A8.8 screws)

Threads of mounting holes: M6x18; M10x18



## 13 - DSPE8J\* - OVERALL AND MOUNTING DIMENSIONS

dimensions in mm

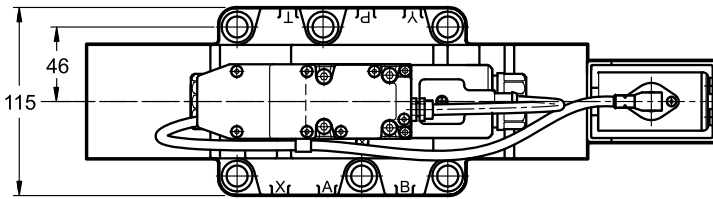
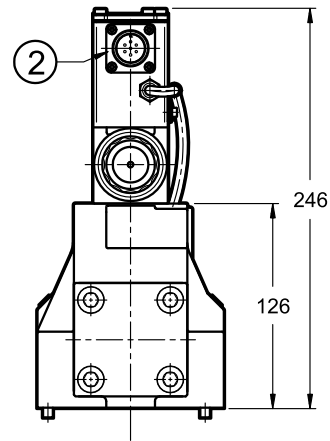
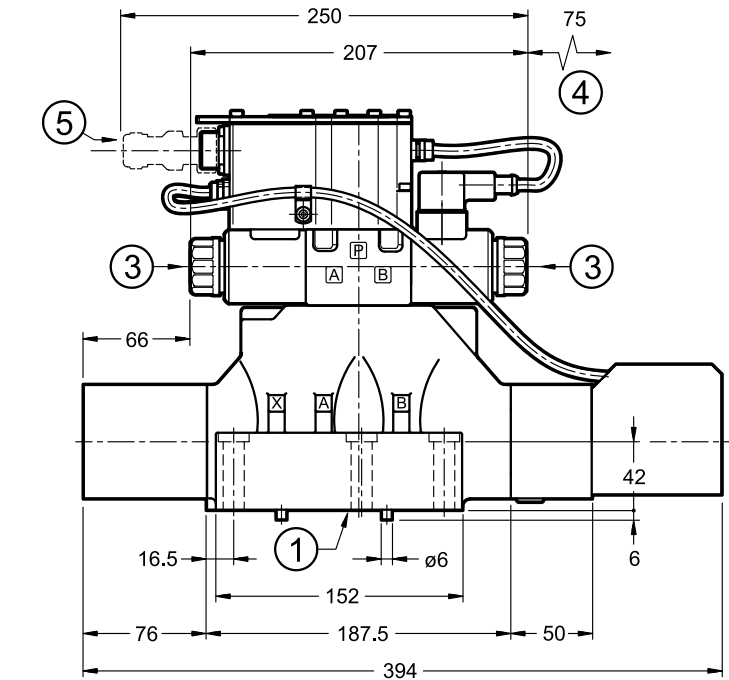

DSPE8JL

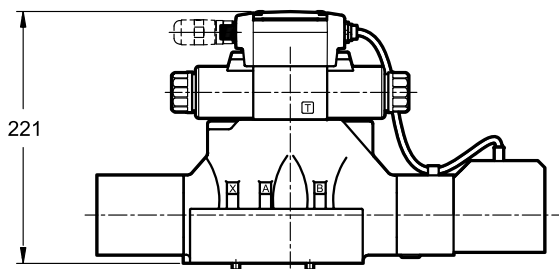

DSPE8JH

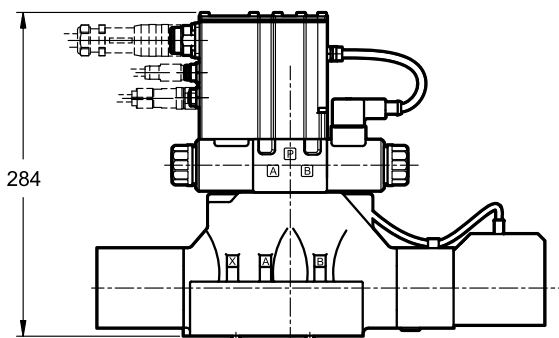

### NOTES:

- Overall dimensions with Z option (fixed adjustment pressure reducing valve) at par. 15.
- Mounting surface at par. 16.
- It is recommended to not disassemble the transducer.

1	Mounting surface with sealing rings: 4 OR type 3118 (29.82x2.62) - 90 Shore 2 OR type 3081 (20.24x2.62) - 90 Shore
2	Main connection 6 pin + PE
3	Manual override embedded in the solenoid tube
4	Coil removal space
5	Mating connector. <b>To be ordered separately.</b> See catalogue 89 000

Valve fastening: 6 SHC screws M12x60 ISO 4762

Tightening torque: 69 Nm (A8.8 screws)

Threads of mounting holes: M12x20

14 - DSPE10J\* / DSPE11J\* - OVERALL AND MOUNTING DIMENSIONS

dimensions in mm

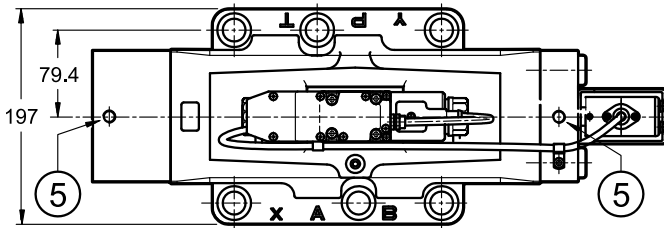
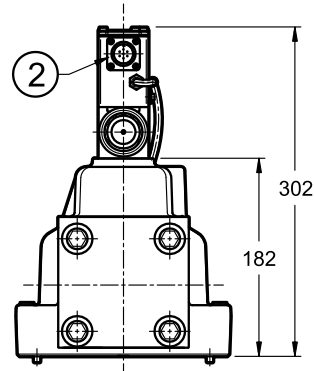
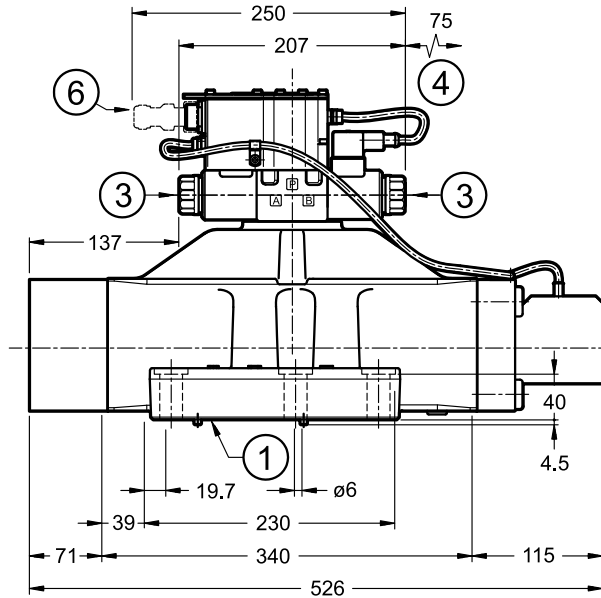

DSPE10JL

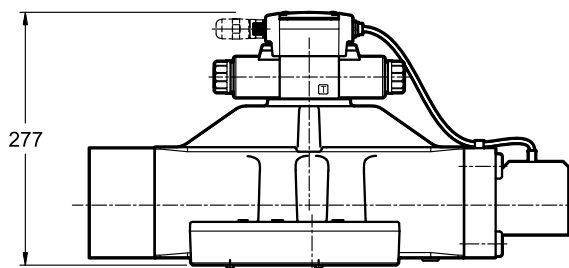

DSPE10JH

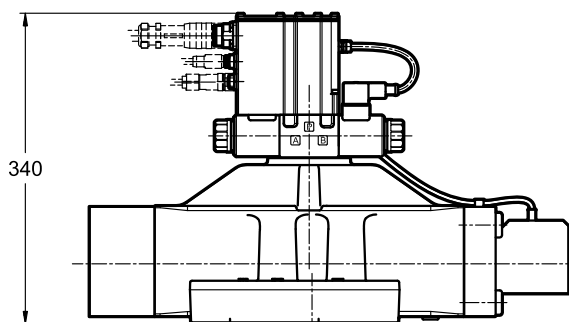

NOTES:

- Overall dimensions with Z option (fixed adjustment pressure reducing valve) at par. 15.
- Mounting surface at par. 16.
- It is recommended to not disassemble the transducer.

1	Mounting surface with sealing rings: <b>DSPE10J*</b> 4 OR type 4150 (37.59x3.53) - 90 Shore 2 OR type 3081 (20.24x2.62) - 90 Shore <b>DSPE11J*</b> 4 OR type 4212 (53.57x3.53) - 90 Shore 2 OR type 3081 (20.24x2.62) - 90 Shore
	2 Main connection 6 pin + PE
3	Manual override embedded in the solenoid tube
4	Coil removal space
5	M12 eyebolt seat for safe lift
6	Mating connector. <b>To be ordered separately.</b> See catalogue 89 000

Valve fastening:  
6 SHC screws M20x70 ISO 4762

Tightening torque: 330 Nm (A8.8 screws)

Threads of mounting holes: M20x40



## 16 - MOUNTING SURFACES

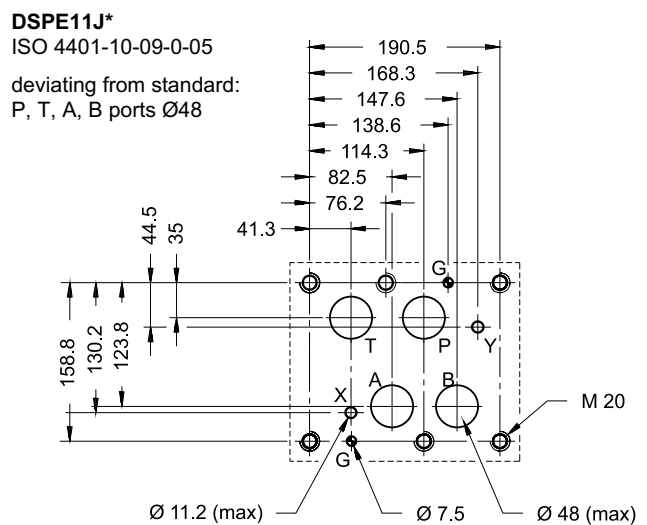
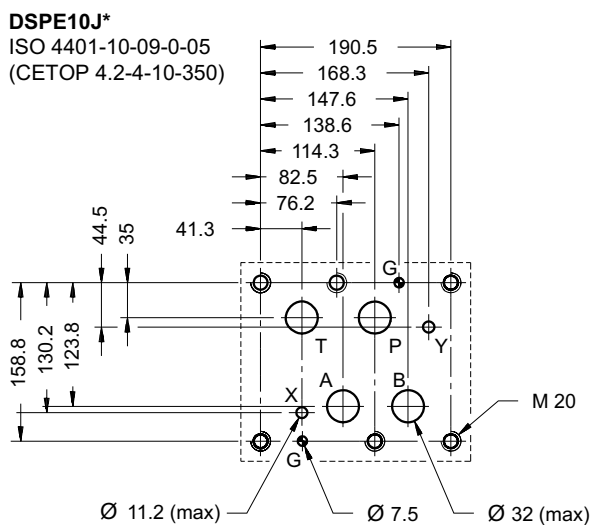
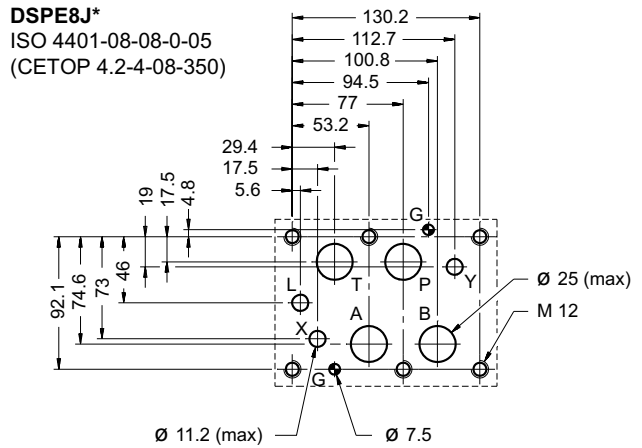
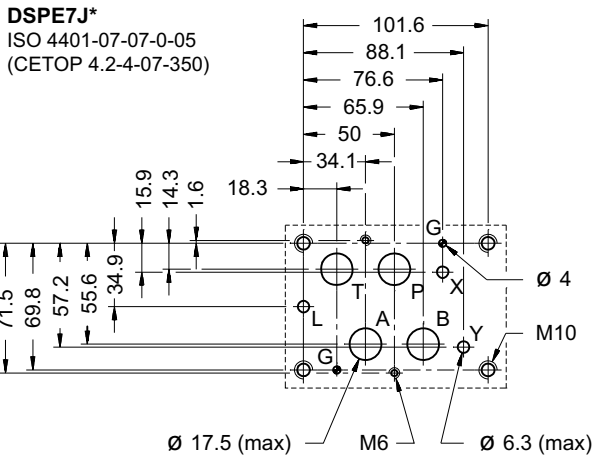
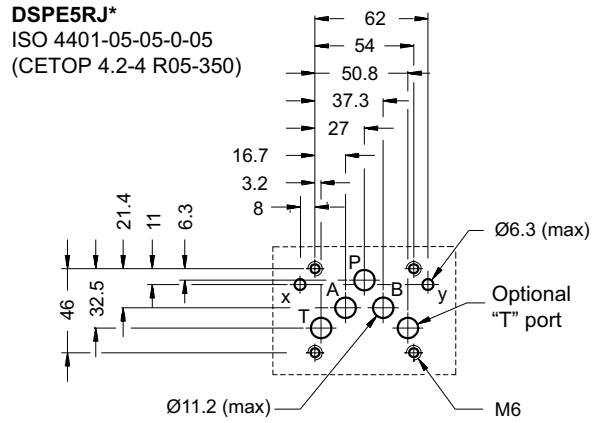
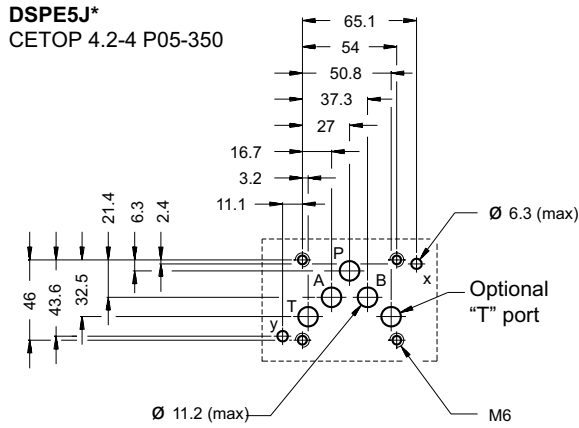

## 17 - HYDRAULIC FLUIDS

Use mineral oil-based hydraulic fluids HL or HM type, according to ISO 6743-4. For these fluids, use NBR seals. For fluids HFDR type (phosphate esters) use FPM seals (code V). For the use of other kinds of fluid such as HFA, HFB, HFC, please consult our technical department.

Using fluids at temperatures higher than 80 °C causes a faster degradation of the fluid and of the seals characteristics.

The fluid must be preserved in its physical and chemical characteristics.

## 18 - INSTALLATION

The valves can be installed in any position without impairing correct operation.

Ensure that there is no air in the hydraulic circuit.

Valves are fixed by means of screws or tie rods on a flat surface with planarity and roughness equal to or better than those indicated in the relative symbols. If minimum values are not observed, fluid can easily leak between the valve and support surface.

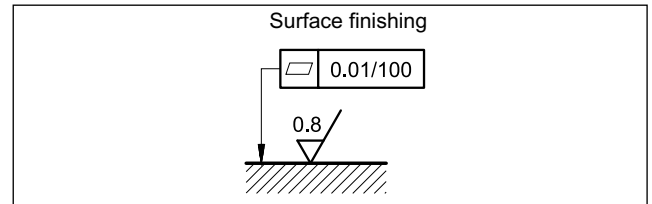

## 19 - ACCESSORIES

(to be ordered separately)

### 19.1 - Mating connectors

Mating connectors must be ordered separately. See catalogue 89 000.



For K11 and K16 versions we recommend the choice of a metal connector to avoid electromagnetic disturbances and to comply with EMC regulations on electromagnetic compatibility. If you opt for a plastic connector, make sure that it guarantees and maintains the IP and EMC protection characteristics of the valve.

### 19.2 - Mating connectors for fieldbus communication and for sensors.

Duplomatic offers spare parts to be wired and also ready-to-use cord sets. Please refer to cat. 89 000.

### 19.3 - Connection cable

The optimal wiring provides for 7 isolated conductors, with separate screen for the signal wires (command, monitor) and an overall screen.

Cross section for power supply:

- up to 20 m cable length : 1,0 mm<sup>2</sup>
- up to 40 m cable length : 1,5 mm<sup>2</sup> (IO-Link excluded)

Cross section for signals (command, monitor):

- 0,50 mm<sup>2</sup>

### 19.4 - Kit for start-up LINPC-USB

Device for service start-up and diagnostic, available for valves with K11 and K16 connections. See catalogue 89 850.

## 20 - SUBPLATES

(see catalogue 51 000)

No subplates are available for DSPE5RJ\*, DSPE10J\* and DSPE11J\*.

	DSPE5J*	DSPE7J*	DSPE8J*
Type with rear ports	PME4-AI5G	PME07-AI6G	-
Type with side ports	PME4-AL5G	PME07-AL6G	PME5-AL8G
P, T, A, B ports dimensions	3/4" BSP	1" BSP	1 1/2" BSP
X, Y ports dimensions	1/4" BSP	1/4" BSP	1/4" BSP



# DSPE\*J\*



**DIPLOMATIC MS S.p.A.**

via M. Re Depaolini 24 • 20015 PARABIAGO (MI) • ITALY

tel. +39 0331.895.111 • [www.diplomatic.com](http://www.diplomatic.com) • e-mail: [sales.exp@diplomatic.com](mailto:sales.exp@diplomatic.com)